



Research Paper

STRESS ANALYSIS OF HELICAL GEAR BY FINITE ELEMENT METHOD

Govind T Sarkar^{1*}, Yogesh L Yenarkar¹ and Dipak V Bhope¹

*Corresponding Author: Govind T Sarkar, ✉ govind.sarkar@gmail.com

The bending and surface stresses of gear tooth are major factor for failure of gear. Pitting is a surface fatigue failure due to repetitions of high contact stresses. This paper investigates finite element model for monitoring the stresses induced of tooth flank, tooth fillet during meshing of gears. The involute profile of helical gear has been modeled and the simulation is carried out for the bending and contact stresses and the same have been estimated. To estimate bending and contact stresses, 3D models for different helical angle, face width are generated by modeling software and simulation is done by finite element software packages. Analytical method of calculating gear bending stresses uses AGMA bending equation and for contact stress AGMA contact equation are used. It is important to develop appropriate models of contact element and to get equivalent result using Ansys and compare the result with standard AGMA stress.

Keywords: Gear, Helical gear, Bending stress, Contact stress, FE method

INTRODUCTION

One of the best methods of transmitting power between the shafts is gears. Gears are mostly used to transmit torque and angular velocity. The rapid development of industries such as vehicle, shipbuilding and aircraft require advanced application of gear technology. Customers prefer cars with highly efficient engine. This needed up a demand for quite power transmission. Automobile sectors are one of the largest manufacturers of gears. Higher reliability and lighter weight gears are

necessary to make automobile light in weight as lighter automobiles continue to be in demand. The success in engine noise reduction promotes the production of quieter gear pairs for further noise reduction. The best way of gear noise reduction is attained by decreasing the vibration related with them.

In this paper real involute gear pair with transmission ratio is analyzed. The properties of gear pair are, number of teeth T_1 and $T_2 = 25$, Std. tooth profile, face width $b = 72.86$ mm. Module $m_n = 5$ mm, Pressure angle = 20° ,

¹ Mechanical Department, RCERT, Chandrapur, MS.

Rotational speed of gear = 1440 rpm. Gear torque = 132.63 Nm, material steel $E = 21000$ N/mm². Poisson ratio $\nu = 0.3$, gear with right and left inclination of teeth is to be modeled. F_t = tangential force (N), b = face width, m_n = normal module, Φ = pressure angle, E = young's modulus, ν = poisson ratio, i = module.

BENDING EQUATION

Bending failure and pitting of the teeth are the two main failure modes in a transmission gearbox. The bending stresses in a helical gear are another interesting problem. When loads are too large, bending failure will occur. Bending failure in gears is predicted by comparing the calculated bending stress to experimentally-determined allowable fatigue values for the given material. This bending stress Equation (1) was derived from the Lewis formula. Bending Stress is given by

$$\tau_b = \frac{F_t P d}{b Y} \quad \dots(1)$$

Y is called the Lewis form factor. The Lewis equation considers only static loading and does not take the dynamics of meshing teeth into account.

The maximum stress is expected at the point which is a tangential point where the parabola curve is tangent to the curve of the tooth root fillet called parabola tangential method. Two points can be found at each side of the tooth root fillet. The stress on the area connecting those two points is thought to be the worst case.

The AGMA equation for bending stresses given by,

$$\tau_b = \frac{F_t}{b m_n J} K_V K_O K_S (0.93 K_m) \quad \dots(2)$$

where K_a = Application factor, K_s = Size factor, K_m = Load distribution factor, K_V = Dynamic factor, F_t = Normal tangential load, J = Geometry factor.

HERTZ CONTACT STRESS (INVOLUTES GEAR TOOTH CONTACT STRESS ANALYSIS)

One of the main gear tooth failure is pitting which is a surface fatigue failure due to repetition of high contact stresses occurring in the gear tooth surface while a pair of teeth is transmitting power. Contact failure in gears is currently predicted by comparing the calculated Hertz contact stress to experimentally determined allowable values for the given material. The method of calculating gear contact stress by Hertz's Equation (2) originally derived for contact between two cylinders.

In machine design, problems frequently occurs when two members with curved surfaces are deformed when pressed against one another giving rise to an area of contact under compressive stresses. Of particular interest to the gear designer is the case where the curved surfaces are of cylindrical shape because they closely resemble gear tooth surfaces. The surface compressive stress (Hertzian stress) is found from the equation

$$\tau_c = \sqrt{\frac{F_t}{f B \cos \psi} \times \frac{\frac{1}{r_1} + \frac{1}{r_2}}{\frac{1 - \nu_1^2}{E_1} + \frac{1 - \nu_2^2}{E_2}}} \quad \dots(3)$$

$$r_1 = \frac{d_p \sin \psi}{2}, \quad r_2 = \frac{d_g \sin \psi}{2}$$

AGMA Contact Stress Equations

$$\tau_c = C_p \sqrt{\frac{F_t \left(\frac{\cos\{\}}{0.95CR} \right) K_v K_o (0.93 K_m)}{bdI}} \dots(4)$$

$$C_p^2 = \left\{ \frac{1}{\frac{1-\nu_1^2}{E1} + \frac{1-\nu_2^2}{E2}} \right\}$$

$C_p = 190.3 \text{ (MPa)}^{0.5}$ for steel (Bhandari, 2012)

where

$$CR = \left(\frac{\sqrt{(r1+a)^2 - rb1^2} + \sqrt{(r2+a)^2 - rb2^2} + (r1+r2)\sin\{\}}{f \ m\cos\{\}} \right)$$

$$I = \frac{\sin\{\} \cos\{\}}{2} \frac{i}{i+1}$$

The Hertz equations discussed so far can be utilized to calculate the contact stresses which prevail in case of tooth surfaces of two mating helical gears. Though an approximation, the contact aspects of such gears can be taken to be equivalent to those of cylinders having the same radii of curvature at the contact point as the load transmitting gears have. Radius of curvature changes continuously in case of an involutes curve, and it changes sharply in the vicinity of the base circle.

PARAMETRIC MODELING OF HELICAL GEAR

Parametric modeling allows the design engineer to let the characteristic parameters of a product drive the design of that product. During the gear design, the main parameters that would describe the designed gear such as module, pressure angle, and root radius, and tooth thickness, number of teeth could be

used as the parameters to define the gear as shown in Table 1.

Table 1: Dimensions of Helical Gear		
S.No.	Data	Gear
1.	Power (KW)	20 x 10 ³
2.	Speed (rpm)	1440
3.	Teeth	25
4.	Normal module (mm)	5.18
5.	Pressure angle	20
6.	Helix angle	15
7.	Transverse module (mm)	5
8.	Pitch dia. (mm)	129.5
9.	Pitch (mm)	16.27
10.	Pa (mm)	60.72
11.	Face width (b) (mm)	72.86
12.	Velocity m/s	9.76
13.	db1 (mm)	121.7
14.	Addendum (mm)	5
15.	Dedendum (mm)	6.25
16.	Torque (Nm)	132.63

But, the parameters do not have to be only geometric. They can also be key process information such as case hardening specifications, Quality of grades, metallurgical properties and even load classifications for the gear being designed.

In this paper work, module, pressure angle, numbers of teeth of both the gears are taken as input parameters. Pro/Engineer uses these parameters, in combination with its features to generate the geometry of the helical gear and all essential information to create the model. By using the relational equation in Pro/Engineer, the accurate three dimensional helical gear models are developed.

CAD software packages allow for modeling and simulation of 3D parametric modeling of

helical gear. It also a good interface with Finite Element software. ProE has model the involute profile helical gear geometry perfectly. For helical gear in ProE, relation and equation modeling is used. Relation is used to express dependencies among the dimension needed for defining the basic parameters on which the model is depends.

For that, go through tool>parameter>menu. Insert all the needed basic gear parameter into the dialogue box and also insert the design parameter as shown in Table 2.

Table 2: Design Parameter for Helical Gear

Variable Name	Value	Description
Z	25	No. of Teeth
D	129.5	Pitch Diameter (mm)
P	16.27	Diametrical Pitch (mm)
PHI	20°	Pressure Angle

The above parameter determine the remaining all parameters that define tooth profile. After the circular disc is extruded having diameter equal to addendum diameter and thickness equal to face width.

Next step is to generate datum involute curve through equation function. Then involute curve used in a sketch to make extruded cut through the gear blank and tooth space is generated. After single tooth space is generated it has to be patterned along the centre axis of gear blank. The helical gear model created after patterning the tooth space as shown in Figure 1. The gear profile is cut through extrude such that to get single teeth with gear blank as shown in Figure 2.

The assembly of gear is done by consider the left and right helical gear. Then the file is saved as IGES format.

Figure 1: Assembly of Helical Gear

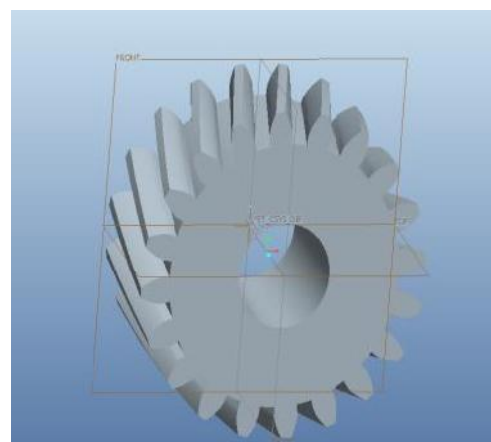
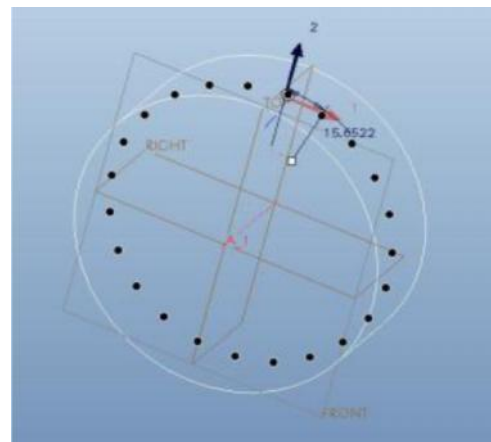
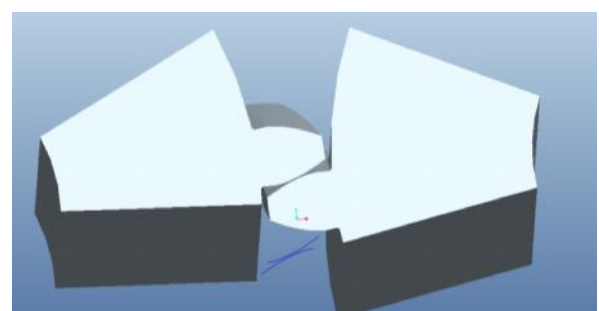

Figure 2: Assembly of Helical Gear



3D Analysis of Helical Gear

For analysis of 3D model of gear, import the IGES file by select the static analysis from menu then connect the geometry to analysis tab. Once the geometry is loaded with static analysis tab, next is to define contact between

the two involute teeth profile. The CAD Commercial software automatically reads the attached geometry for predefined contact. The teeth contact between two teeth is set as frictionless. Default setting for mesh generation is not sufficient to get accurate result. For that select proper relevance with smoothing and span angle. For boundary condition, frictionless support is given to gears as shown in Figure 4 and Torque $T = 132.63$ Nm is applied to the left helical gear in clockwise direction.

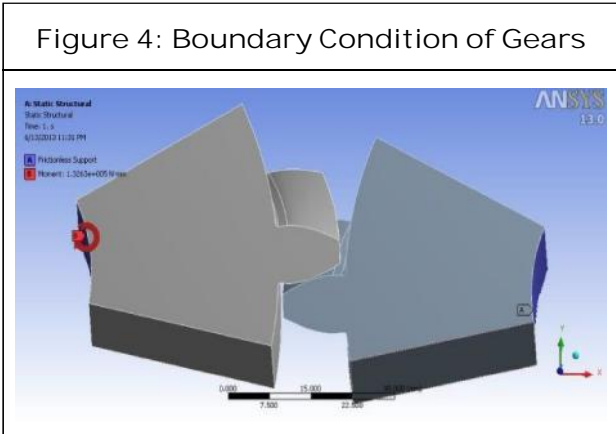
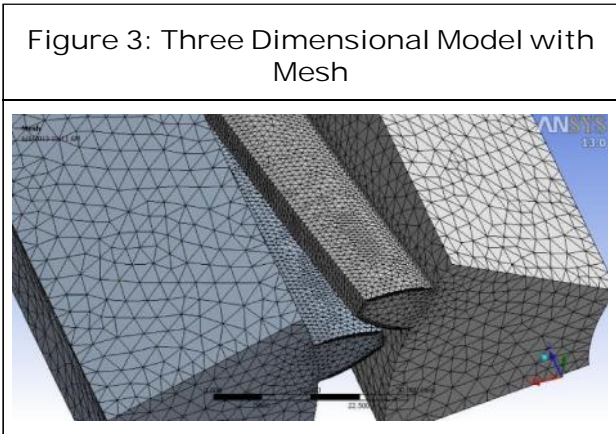

AGMA BENDING AND CONTACT STRESS ANALYSIS OF HELICAL GEAR

AGMA Bending Stress

As per AGMA standard equation the bending stresses are as:

$$\tau_b = \frac{Ft}{bm_n J} K_V K_O (0.93 K_m)$$

$$\tau_b = 27.21 \text{ N/mm}^2$$

AGMA Contact Stress

As already mentioned high contact stresses results in pitting failure of the gear tooth, it is necessary to keep contact stresses under limit. As per AGMA contact stress equation are used as:

$$\tau_c = C_p \sqrt{\frac{FT \left(\frac{\cos\{\}}{0.95CR} \right) K_V K_O (0.93 K_m)}{bdl}}$$

$$\tau_c = 190.31 \sqrt{\frac{2048.33 \left(\frac{\cos 15}{0.95 * 1.536} \right) 1.252 * 1 * 0.93 * 1.5}{72.86 * 129.5 * 0.140}}$$

$$\tau_c = 258.1 \text{ MPa}$$

FEM RESULTS FOR BENDING STRESS OF HELICAL GEAR

Helical gear assembly was imported in ANSYS 13 and the boundary conditions were applied to the gear model. The model was analyzed for the root bending stress for the applied tangential, axial and radial force. In helical gear only 3-D analysis was performed

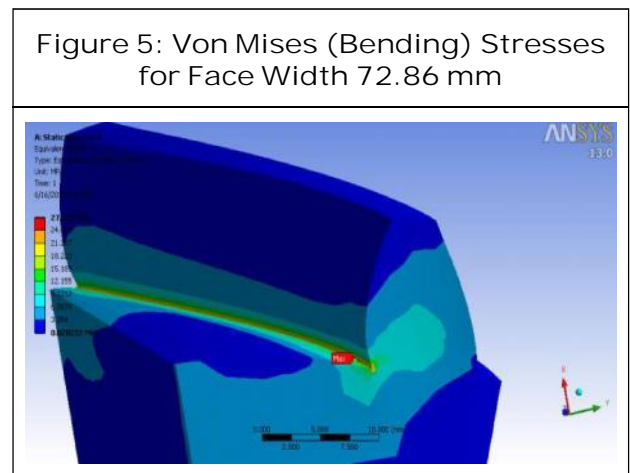

Figure 6: Von Mises (Bending) Stresses for Face Width 55 mm

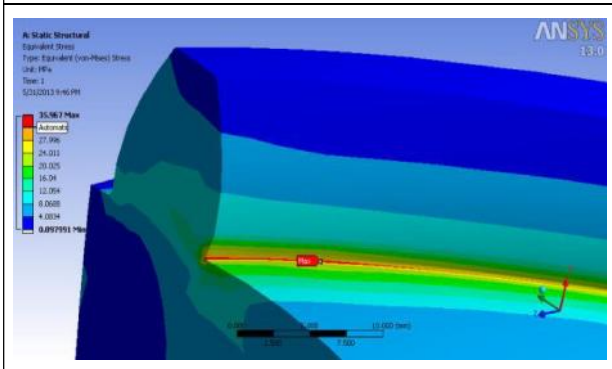
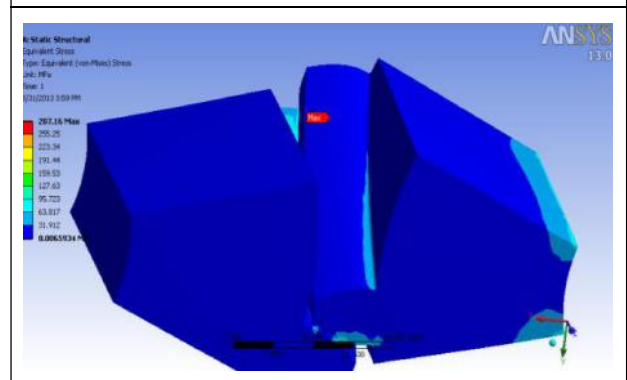

Figure 8: Von Mises (Contact) Stresses for Helix Angle 20°



because of the helical profile of its teeth. The Figures 5 and 6 shows the stress distribution plot along the tooth.

FEM RESULTS FOR CONTACT STRESS OF HELICAL GEAR

Contact stresses were studied in the same manner as bending stresses were calculated. In this paper Von Mises Contact stresses are obtained at the contact region. The Figures 7 and 8 shows the stress distribution plot along the tooth.

COMPARISON

In this section the modeled helical gear is analyzed to study the effect of face width, helix angle on bending and contact stress under

static load with different parameters. Throughout the analysis each gear is studied for five different face widths ($b = 32.8 \text{ mm}, 37.67 \text{ mm}, 44.62 \text{ mm}, 55 \text{ mm}, 72.76 \text{ mm}$), for five different helix angles ($j = 15^\circ, 20^\circ, 25^\circ, 30^\circ, 35^\circ$). All the rest parameters and the applied load are kept constant.

Effect of Helix Angle

In this part of the work, apart from the constant number of teeth, module and pressure angle. The face width is also kept constant and the helix angle is varied from 15° to 35° in steps of 5° . The maximum contact stresses obtained are shown in Table 3 and it is observed from the Figure 9, there is a variation in the maximum contact stresses with the change in helix angle. The maximum contact stress value

Figure 7: Von Mises (Contact) Stresses for Helix Angle 15°

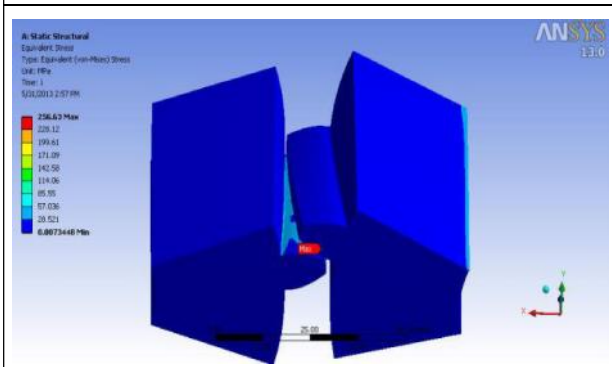
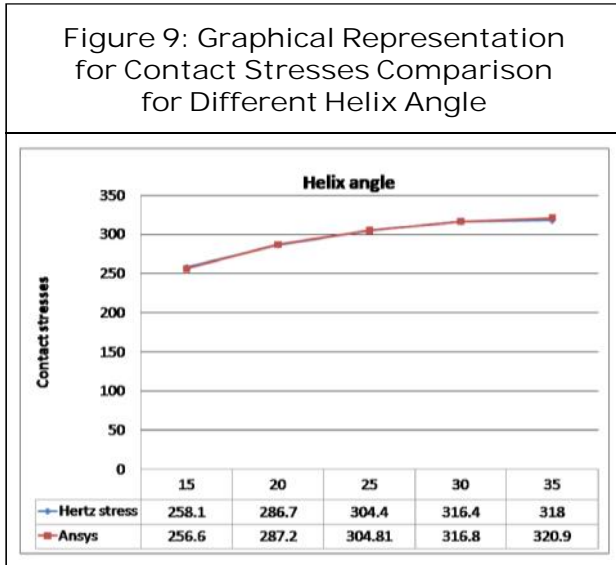

Table 3: Comparison of Values of the Contact Stresses by Considering Different Helix Angle

Helix Angle	Hertz Stress (MPa)	Vonmises (Ansys) (MPa)
15	258.10	256.63
20	286.70	287.16
25	304.40	304.81
30	316.42	316.83
35	318.00	320.89

increases with the increase of helix angle which is in close agreement with values obtained from AGMA formula.



Effect of Face Width

The effect of face width on maximum bending stress is studied by varying the face width for five different values which are ($b = 32.8$ mm, 37.67 mm, 44.62 mm, 55 mm, 72.76 mm). The maximum bending stresses obtained are shown in Table 4 and it is observed from the Figure 10, there is a variation in the maximum bending stresses with the change in face width. The maximum bending stress value decreases with the increase of face width.

Table 4: Comparison of Values of the Root Bending Stresses by Considering Different Face Width

Face Width (b) (mm)	Root Bending Stress (MPa)	Root Bending Stress (Ansys)
72.86	27.21	27.33
55	35.02	35.97
44.62	41.93	43.38
37.67	47.71	49.13
32.84	52.11	51.94

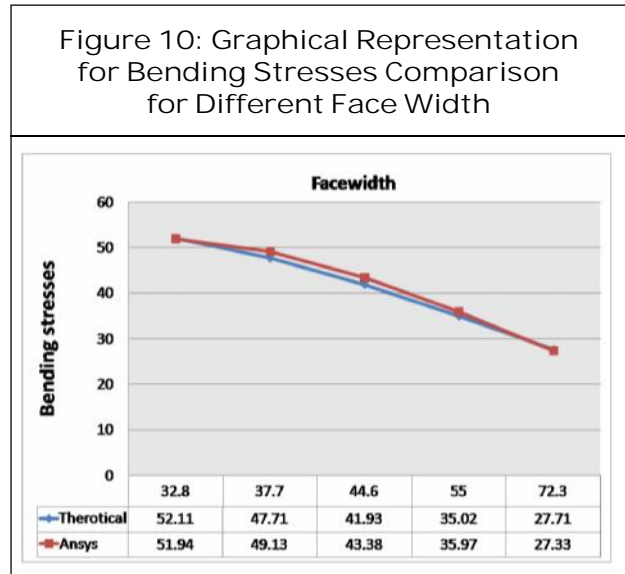

CONCLUSION

Tooth design conventionally based on bending theory. In case of helical the nature of contact between the mating teeth demands some investigation in contact stress. The AGMA has provided the empirical relation for bending as well contact stress. The lewis theory and the hertzian approach also provide the relation of bending and contact stresses respectively.

The work done primarily focused on validation of the AGMA and lewis and hertzian theory using FE approach. The geometric modeling of helical tooth profile was done and it was suitably constraint and loaded to create FE model after meshing the same. The mesh size and type of elements were selected after necessary considerations. The no. of elements was decided by gradually increasing them till the stress and deflection did not show the significant changes.

Models are made for helix angle, face width. Each of the geometry was converted for FE model and analyzed and analyses the result obtain in analysis were compared with AGMA std. and Lewis and herztian approaches. The

results obtained are close to theoretical/empirical results.

It can be concluded that the helix angle is critical for contact stress as increasing helix angle increases contact stresses because it increases length of contact is the area.

Face width increased causes decreases the bending stresses as bearing area at the root increases.

The face width and helix angle are an important geometrical parameters during the design of gear. As it is expected, in this work the maximum bending stress decreases with increasing face width and it will be higher on gear of lower face width with higher helix angle. As a result, based on this finding if the material strength value is criterion then a gear with any desired helix angle with relatively larger face width is preferred. ●

REFERENCES

1. Bhandari V B (2012), *Design of Machine Elements*, 2nd Edition, Tata McGraw Hill Publishing Compan Limited.
2. Boddu Anil Kumar (2012), "Design, Modeling and Analysis of Helical Gear", August, pp. 1-6.
3. "Design Data Book", Central Techno Publications, Nagpur, India.
4. Gautam V Varde (2012), "Contact Stress Analysis of Spur Gear", June, pp. 1-7.
5. Ivana Atanasovska and Vera Nikolic (2009), "Finite Element Model for Stress Analysis and Nonlinear Contact Analysis of Helical Gear", pp. 61-68.
6. Kailesh Bhosale (2011), "Analysis of Bending Strength of Helical Gear by FEM", pp. 125-129.
7. Lu J, Litivin F and Chen J S (1995), "Load Share and Finite Element Stress Analysis for Double Circular-Arc Helical Gears", *Math. Comput. Modeling*, Vol. 21, pp. 13-30.
8. Negash Alemu (2009), "Analysis of Stresses in Helical Gears by Finite Element Method", pp. 1-55.
9. Venkatesh B, Kamala V and Prasad A M K (2010), "Design, Modelling and Manufacturing of Helical Gear", pp. 103-114.
10. Venkatesh B, Kamala V and Prasad A M K (2011), "Parametric Approach to Analysis of Aluminum Alloy Helical Gear for High Speed Marine Application", pp. 173-178.
11. Zeping Wei (2004), "Stresses and Deformations in Involute Spur Gears by Finite Element Method", pp. 1-108.