



Research Paper

STRESS ANALYSIS OF VARIOUS TYPES OF RIVETED LAP JOINT

Suyogkumar W Balbudhe^{1*}, S R Zaveri¹ and Y L Yenarkar¹

*Corresponding Author: Suyogkumar W Balbudhe, ✉ Suyog24@yahoo.co.in

This project deals with the stress analysis of various arrangements of riveted lap joints (Chain riveting, zigzag riveting and diamond riveting). This work involves the appropriate configuration and characterization of these joints for maximum utilization. By using finite element method, stress analyses are carried out under both the residual stress field and external tensile loading. Using a two step simulation, riveting process and subsequent tensile loading of the lap joint are simulated to determine the residual and overall stress state. Residual stress state due to riveting is obtained by interference and clamping misfit method. By employing different interference and clamping misfit values, the effects of riveting process parameters on stress state are examined. Two cracks namely the semi elliptical surface crack at faying surfaces of plates and the quarter elliptical corner crack at rivet hole are the most widely observed crack types in riveted joints. Fracture analysis of cracked riveted joints is carried out by introducing these two crack types to the outer plate at a plane perpendicular to the loading. The finite element technique was used throughout the analysis of present work. The present work showed that riveted joints are superior in strengthening to the riveted joints. The riveted joint seems to strengthen and balance the stress and distributed uniformly. This improves the efficiency and life time of the riveted joints. Modeling is done by CATIA V5R20 and analysis of riveted lap joint done by using ANSYS (Workbench) with a version of 14.0.FEM result can be analyzed with each other.

Keywords: Riveted lap joint, Ansys workbench V14.0, Finite element technique

INTRODUCTION

Manufacturing large and complex structures is usually possible only when they are composed of assemblies of smaller parts joined together by variety of joining techniques since most

products are impossible to be produced as a single piece. Manufacturing components and then joining them into a single product is easier and less expensive than manufacturing the whole product at once. In order to ensure

¹ Mechanical Department, Rajiv Gandhi College of Engineering, Research and Technology, Chandrapur (M.S.), India.

the manufacturability, and reduce the overall manufacturing cost, certain fastening and joining methods should be utilized. Mechanical fasteners can be described as devices that mechanically join two or more objects of an assembly with desired permanence, stability, and strength. Mechanical fasteners offer several options for joining and fastening mechanical components together. Mechanical fastening methods can be categorized into two main types: permanent (welding, bonding, riveting, etc.), and detachable joints (bolt, screw, pin, etc.). Selection of appropriate method among these alternatives should be based on permanence, cost and strength of the fastener.

DESIGN STRESSES

The rivet joints are analyzed on the basis of following assumptions:

- Rivets are loaded in shear the load is distributed in proportion to the shear area of the rivets
- There are no bending or direct stresses in rivets
- Rivet holes in plate do not weaken the plate in compression
- Rivets after assembly completely fills the hole
- Friction between the adjacent surfaces does not affect the strength of the joints however the actual stress produced decreases
- When rivet is subjected to double shear, the shear force is equally distributed between the two areas of shear

Thus according to the theory the failure of rivet may occur due to any one of the following modes.

Theories of Failures of Rivet Joints

Tearing of the Plate at an Edge: A joint may fail due to tearing of the plate at an edge as shown in below Figure 1. This can be avoided by keeping the margin, $m = 1.5d$, where “ d ” is the diameter of the rivet.

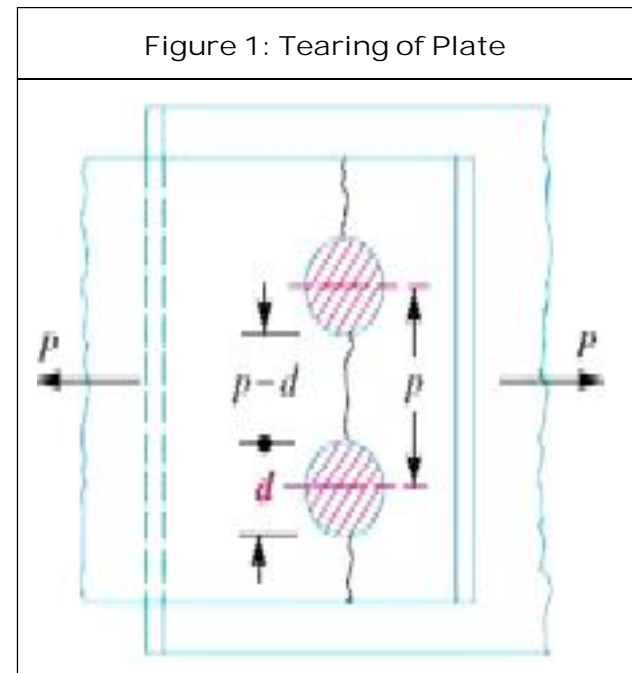

Tearing of the Plate Across a Row of Rivet:

Tearing resistance required to tear off the plate per pitch length, $P_t = A_t \cdot \sigma_t = (p-d)t \cdot \sigma_t$

where

p = Pitch of the rivets;

d = Diameter of the rivet hole;

t = Thickness of the plate;

σ_t = Permissible tensile stress for the plate material.

Shearing of Rivet

Thus shear strength is,

$P_s = n f / 4 d^2 T_{max}$ - for single shear and

$P_s = 2 \times n f / 4 d^2 T_{max}$ - theoretically in double shear and

$P_s = 1.875 \times n f / 4 d^2 T$ - for double shear, according to Indian boiler regulations

where,

T_{max} = Shear strength of rivet;

n = Number of rivets.

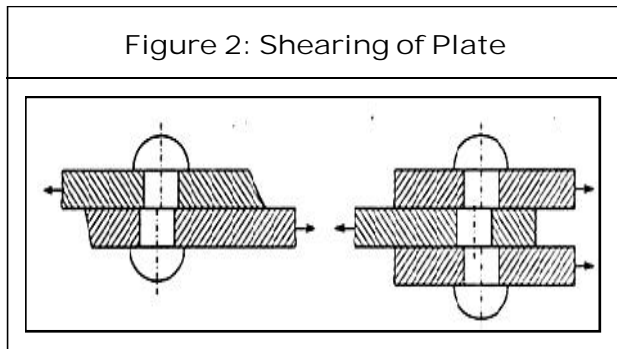

Crushing of the Plate (or) Rivets

The crushing strength is, $P_c = n d t c$

where,

c = Crushing strength of rivet;

n = No of rivets under crushing;

d = Diameter of rivet = $6.1 \sqrt{t}$;

t = Thickness of plate

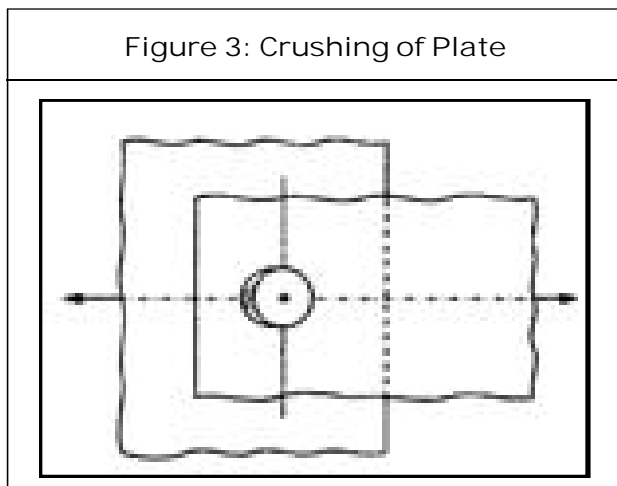

Efficiency of Riveted Joint

$$\eta = \frac{\text{Strength of the joint in the weakest mode}}{\text{Strength of the unpunched plate}}$$

OVERVIEW OF ANSYS

The ANSYS (workbench) V.14.0 computer program is used for multipurpose finite element program, which may be used for solving several different field Engineering analyses. An ANSYS (workbench) V.14.0 has been developed, other special capabilities, such as sub structuring, sub modeling, random vibration, free convection fluid analysis, acoustics, magnetic, piezoelectric, couple field analysis and design optimization have been added to the program.

Program Overview

Analyzed of any problem in ANSYS has to go through three main steps. They are, Pre-processor, Solution and Postprocessor. The input of the ANSYS is prepared using preprocessor. The general preprocessor contains powerful solid modeling and mesh generation capabilities, and is also used to define all the other analysis data such as geometric properties like real constants, material properties, constraints, loads, stiffness damping, etc.

General Procedure to Solve and Problem in ANSYS

The ANSYS software has many finite element analysis capabilities ranging from simple, linear, static analysis to a complex, nonlinear, transient dynamic analysis any problem in ANSYS has to go through the three main steps Build the model, Apply loads and obtain solution Review the results.

Building the Model

In this project model is designed with the help of CATIA V5R20 and also given the material property in this software by providing the proper constraining. This model developed with three

stages first upon developing all the object as a part file single pieces with separate file and then assemble with constrained in assembly, i.e., product environment. Then converted this model into “.stp” format to importing the ANSYS (workbench).

Apply Loads and Obtain the Solution

Applying Loads: Boundary conditions and Different loads acting on the model are applied either in the preprocessor as well as contact surface between the object also given. The loads in the ANSYS program are

- DOF Constraints
- Forces
- Surface loads
- Body loads

Defining the Type of Analysis and Analysis Options Static Analysis: Used to determine displacements, stresses, etc., under static loading conditions. Both linear and nonlinear static analysis. Nonlinearities can include plasticity, stress stiffening, large deflection, large strain, hyper elasticity, contact surfaces, and creep. Our present analysis is “static analysis”.

Specifying Load Step Options: The following path is used to specify load step options.

Main Menu =>Solution =>Insert option

Initiating the Solution: The solution to the given problem is initiated by using the following path.

Main Menu =>Solution =>Solve

Initiating the Results: After the solution any type of result can be seen by following path.

Main Menu =>Solution =>Insert Results

DESCRIPTION OF THE WORK

The work deals with the stress Analysis of riveted lap joint. This is quite commonly used technique for finding the strength of different applications like pressure vessels, aerospace, marine and mostly for leak proof joints like oil tanks, boilers, etc. In this a lap joint of aluminum alloy plate material having 215 mm * 2 mm * 45 mm and a friction factor of 0.2 is over lapped with the other plate having same dimensions and material and are joined by means of a rivet having diameter 4 mm, apply a load of 7200 N on one side and the

Figure 4: Geometric of Riveted Lap Joint

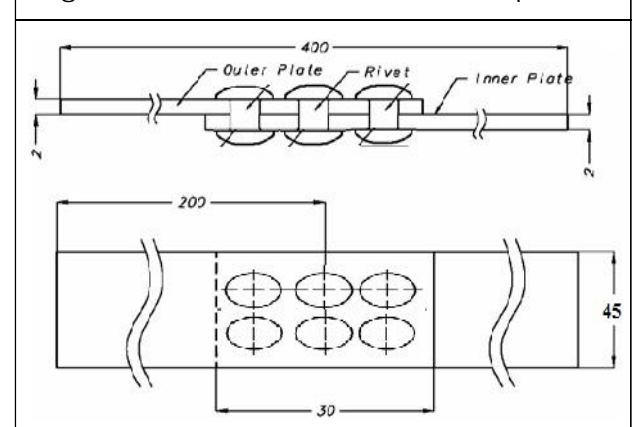
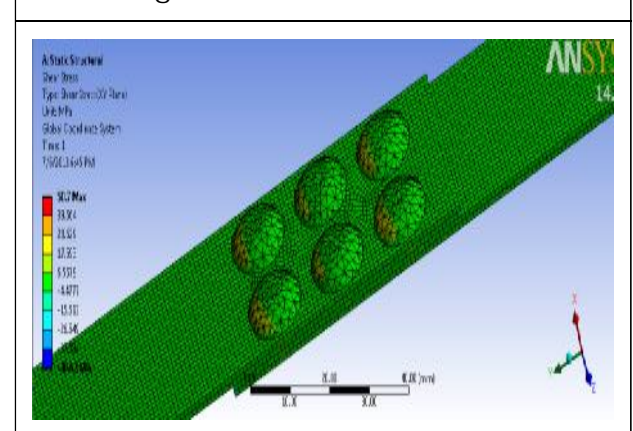

Figure 5: Actual CAD Model



other end is fixed in the ANSYS (workbench). The stresses on normal riveted joint is compared with each other.

Determination of Specifications

The specifications of the present job has taken from the design considerations from the plate thickness as 2 mm and that are specified in the following diagram. Figure 6 shows the configuration, Dimensions, constraints and loading conditions. The following assumptions and boundary conditions were considered throughout the idealization process:

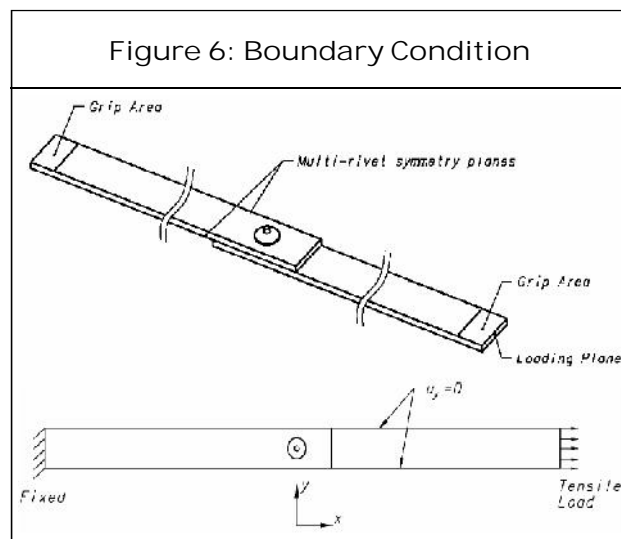

Finite Element Model with Meshing, Boundary Conditions and Material Property

Figure 6 shows the CAD model prepared in CATIA also the property of material given in same software. This model meshed in ANSYS for analysis with element size 0.5 mm brick and triangular meshing with fine type.

Material		Young's Modulus	Poisson's Ratio
Plate	2024-T3	74 GPa	0.33
Rivet	2117-T4	71.7 GPa	0.33

FEM Analysis on Chain Riveting

- Maximum shear stress on rivet
- Shear stress on rivet

FEM Analysis on Zigzag Riveting

- Maximum shear stress on rivet
- Shear stress on rivet

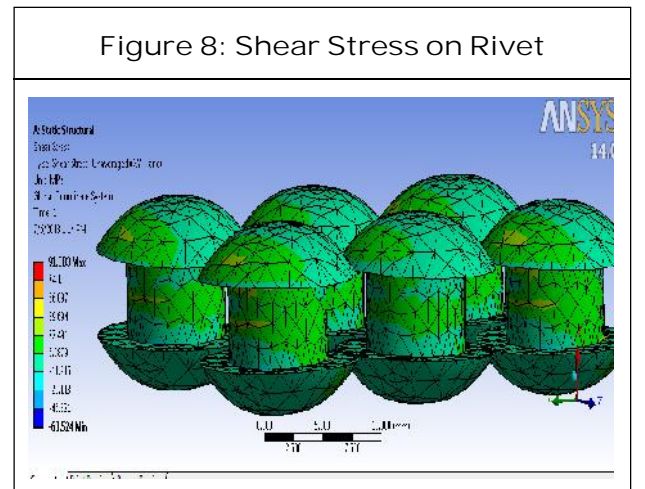
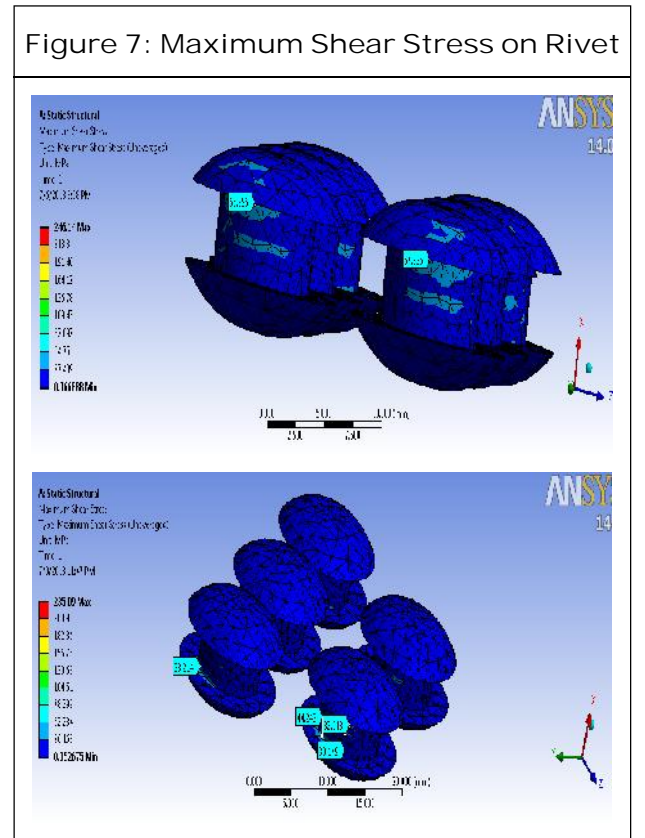

FEM Analysis on Diamond Riveting

- Maximum shear stress on rivet
- Shear stress on rivet

Figure 9: Maximum Shear Stress on Rivet

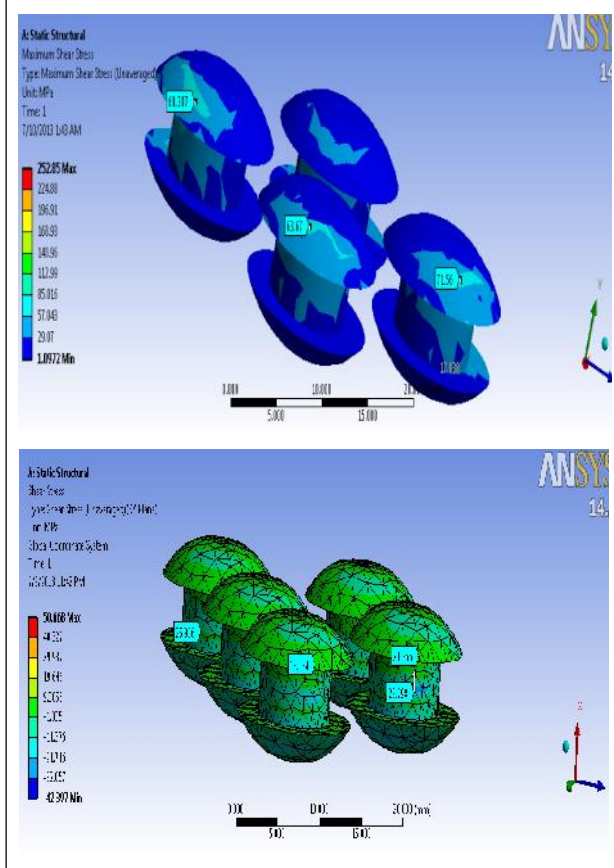
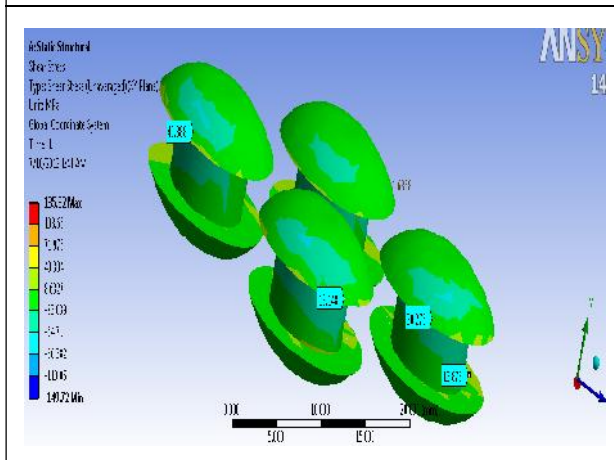

Figure 10: Shear Stress on Rivet



CONCLUSION

The results obtained from ANSYS (Workbench) software for the various types of riveted lap joints are shown in following Table 2.

Type	Shear Stress (Mpa)	Max. Shear Stress (Mpa)
Chain Riveting	58.774	65.654
Zigzag Riveting	29.987-40.327	26.16-52.284
Diamond Riveting	40.30-103.65	57.04-85.01

In chain riveting, developed a new model having two rivets in row and three rivets in column. From this case it is seen that shear stress and maximum shear stress are nearly same but maximum and minimum principal stresses increase with pitch.

In zigzag riveting it is seen that shear and maximum shear stress is decreased.

In diamond riveting it is seen that shear stress and maximum shear stress decreases where as maximum and minimum principal stress increases, however maximum stresses are found to shift on dome of rivet from the shank as seen in previous arrangement upper dome shape of part.

By and large, through all the investigation carried out it can be concluded that the zig-zag riveting process is one of the best process as shear and maximum shear stress on rivet is minimum as compare to other riveting.

SCOPE FOR THE FUTURE WORK

There is a huge scope for the future work, on the resent topic of stress analysis Riveted lap joint.

- By the consideration the design and practical with these we can get some more accurate results.
- By considering a particular application and load leads to a scientific research.
- By changing the thickness of plate and thickness of dome. 🌀

REFERENCES

1. Harris C E, Piascik R S and Newman C (1999), "A Practical Engineering Approach to Predicting Fatigue Crack Growth in Riveted Lap Joints", International Conference on Aeronautical Fatigue (ICAF), Seattle, W.A.
2. Kale Suresh, Murty K L N and Jayananda Kumar T (2008), "Analysis of Adhesively Bonded Riveted Joints".
3. Kurmi R S and Gupta J K (2009), *A Text Book of Machine Design*.
4. Silva L F M, Gonçalves J P M, Oliveira F M F and de Castro P M S T (2000), "Multiple Site Damage in Riveted Lap-Joints: Experimental Simulation and Finite Element Prediction", *Int. J. Fatigue*, Vol. 22, pp. 319-338.
5. Tirupathi R Chandrupatla and Ashok D Belegundu (2011), *Introduction to Finite Elements in Engineering*.