



Research Paper

# DESIGN CONSIDERATION FOR RADIAL ADJUSTABLE BELT CONVEYOR SYSTEM

R K Bhoyar<sup>1\*</sup> and C C Handa<sup>1</sup>

\*Corresponding Author: R K Bhoyar, ✉ [rahulkbhoyar86@gmail.com](mailto:rahulkbhoyar86@gmail.com)

Belt conveyor is the transportation of material from one location to another. Belt Conveyor has high load carrying capacity, large length of conveying path, simple design, easy maintenance and high reliability of operation. In this paper the study is on adjustable height of belt conveyor for variable speed moving in different direction of a belt conveyor system. It transfer material in two different destination from a single source. For that it is required to design all the components of belt conveyor like belt width, belt speed, pulley diameter, chute to transfer the material, etc. This paper attempts to discuss the generalized design consideration for adjustable radial belt conveyor.

Keywords: Belt, Conveyor, Adjustable height, Chute, Radial

## INTRODUCTION

In any industrial process, the product being manufactured passes through various phases and it needs to be transported from place to place. This could involve processes such as transporting of raw material to the machines and then shifting the machines from one station to another station and finally to the store or warehouse. This involves the use of material handling equipment. Simplest form of material handling is to take material from one place to another place manually or with the help of worker. In large production setups, where the production rates are high and the product to be handled is such that manual transportation

is not possible, sophisticated material handling systems would be required.

Basic consideration for selecting material handling system:

- Direction of load travel.
- Length of load travel.
- Properties and characteristics of the material being handled.
- The rate of flow of material.
- Kind of the production process.
- Method of loading and unloading.
- Existing layout and conditions of the work space.

<sup>1</sup> Department of Mechanical Engineering, K.D.K College of Engineering, Nagpur, Maharashtra, India.

- Initial and operational costs.
- Height to which the load is to be carries.
- Working and climatic conditions.
- The capacity of conveying.
- In a conveying system possibility of use of gravity.
- The capacity of handling/conveying equipment should match with the capacity of processing unit or units.
- Spillage of conveyed products should be avoided.
- Pollution of the environment due to noise or dust by the conveying system should also be avoided.

### Belt Conveyor

A belt conveyor is an endless belt operating between two pulleys with its load supported on idlers. The belt may be flat for transporting bagged material or V-shaped. The belt conveyor consists of a belt, drive mechanism and end pulleys, idlers and loading and discharge device. On the belt convey or baggage/product lie still on the surface of belt

and there is no relative motion between the product and belt. This results in generally no damage to material. Belt can be run at higher speeds, so, large carrying capacities are possible. Horizontally the material can be transported to longer distance. The first step in the design of a belt conveyor with a specified conveying capacity is to determine the speed and width of the belt.

### SELECTION OF BELT CONVEYOR COMPONENTS

This subject is dealt with exhaustively in trade literature, and it is only proposed to mention the main points to be consider briefly.

It is then necessary to decide drive unit, belt speed, belt width, idler type and type of belt in order to establish the basic parameters of the conveyor design.

### Drive Unit

The drive unit consist of electric motor, damping coupling, two or three stage gearbox and coupling that connect output shaft with pulley. Gear system helps to adjusting speed to transfer material as per the density of material. Coupling is used to connect motor with gearbox to transfer power.

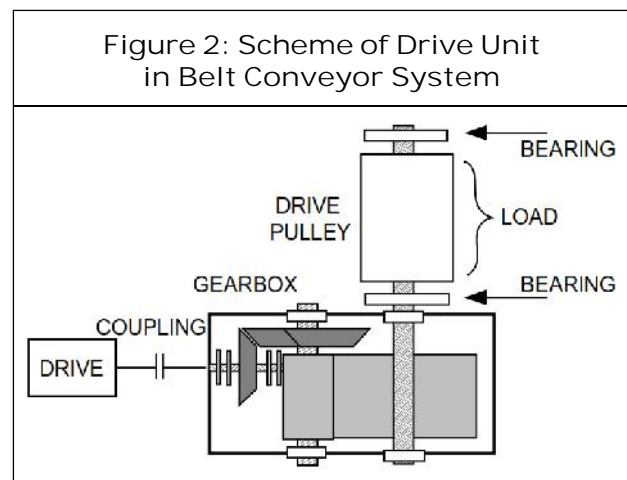
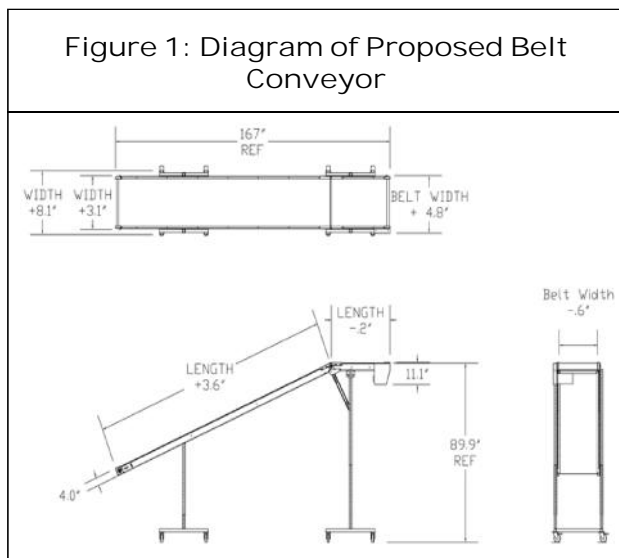

### Structural Frame

Lower frame and the upper frame of the belt conveyor are fabricated from steel sheets and formed in the shape of C channel. Four legs are fabricated from steel angles. Two wheels are fixed to the front side lower frame to facilitate its movement in the field and also used lead screw or piston cylinder (pneumatic or hydraulic) arrangement for movement in up and down direction for adjusting height. The upper frame consists of the belt frame, drums, transmission system, belt, and linen cover.

### Belt Width and Material

How much quantity of material is to be transfer is depend on belt width? Belt width is an important selection components. Width is depend on quantity of material and the type of material is to be transfer. For conveying low weight material belt width is less whereas for conveying high weight material the belt width is vice versa. Conveyor belt is made up of compounds comprised of natural rubbers, styrene-butadiene rubber blends of natural and other synthetics, nitriles, butyl, ethylene propylene-based polymer, polychloroprene, polybutadiene, polyvinyl chloride, urethanes and silicones, etc. Each of those elastomers has specific usefulness for various ranges of properties and operating conditions from

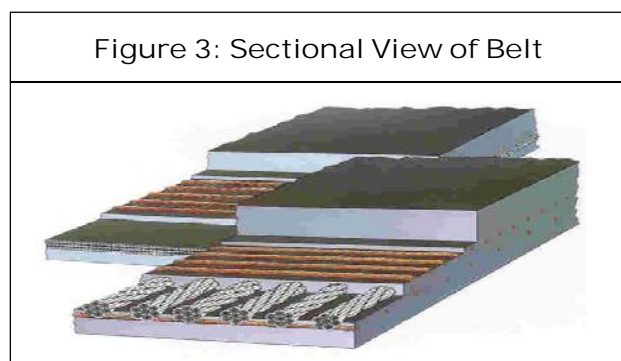

which manufacturers and end-users can choose .

### Belt Speed

Let us in the first instance examine the effect of varying belt speeds. The range of speeds which has been used in belt conveyor design varies 1.5 m/s to 4 m/s. Wider than 30" in order to achieve the desired material transfer rate Wider belts alleviate the loading problem and the highest belt speeds have been used on belts of 48" and 54" width. This choice of parameters gives material transfer rates, depending on the density of the material being handled.

### Idler Type

Drawings of typical idlers of the various types available are shown in Figure. It is only necessary to consider the 20°, 30" and 45" equal roll idlers and the flat return belt rubber tread idler. The other types of idler shown, such

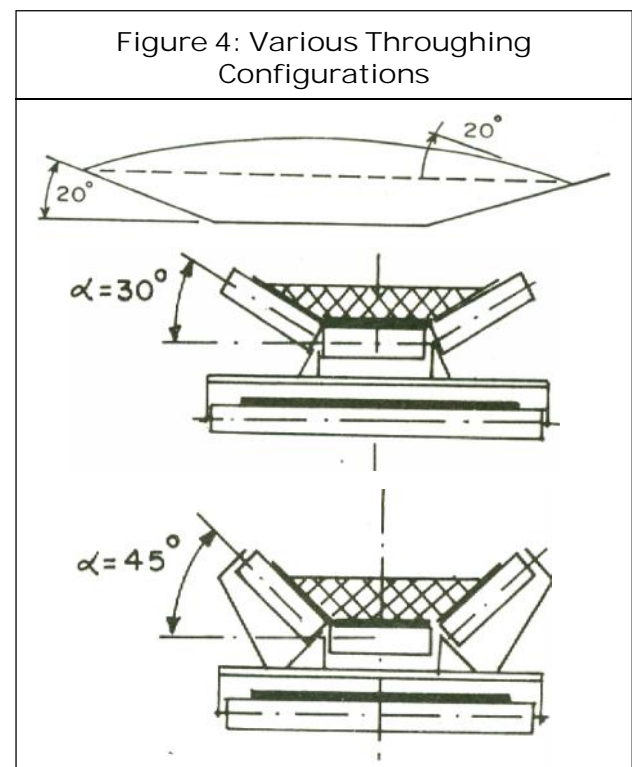

as the troughed-belt cushion idlers and the unequal idlers are special purpose idlers for lumpy products or for picking or sorting belts and such special applications. The 45° throughing idler gives the greatest carrying capacity for any given belt width, but it is essential that an adequately flexible belt be used with it to ensure that sufficient contact is maintained between the belt and the horizontal roll of the idler under no-load conditions if belt tracking problems are to be avoided. Where high duties are involved, the 45° idler is the obvious choice while at lower duties there may be distinct merit in the 30° or even the 20° idler.

#### Belt Training

A major practical problem in the operation of belt conveyors is ensuring that the belt runs reasonably centrally on the idlers. If the belt runs off too far it is liable to be damaged by contact with the conveyor structure, while even before this stage is reached it is possible that excessive spillage may result from a belt running eccentrically. On high-speed belts it has been found to be better practice to line up all idlers and the head and tail pulleys extremely accurately and to dispense entirely with training idlers. On slow-speed belts training idlers can perform a very valuable service, but they cannot be relied upon to ensure that a belt runs true when intermediate idlers are not sufficiently accurately set up.

#### Transfer Chutes

Transfer chutes, as the name implies, are for the purpose of transferring the conveyed material from one conveyor belt to the next one in the sequence. Transfer chutes are the heart of the design of any conveyor installation and the success of the design of the chutes can

make the whole installation. The object is to transfer all the conveyed material from one belt to the next with as little loss of height as possible and without spillage. The feeder box type is probably the best known and may take the form of a large hopper with a trouser leg outlet to guide the material right down to the receiving belt.

#### Guide Plates

These may be attached to the lower edge of the feed plate to provide a degree of adjustment to the central loading of the receiving belt. This is an important aspect of chute design as eccentric loading of belts can be a major cause of problems in tracking the belts.

## DESIGN CALCULATIONS AND PROCEDURES

Both of the description and design calculations of the proposed systems are introduced.

Important factors are to be considered:

- Angle of repose and angle of surcharge
- Flow ability
- Effective belt width for material
- Volume capacity of belt,  $Q$
- Mass capacity of belt
- Belt speed

Select suitable data from design data book for calculation.

- The velocity of the belt in m/s was calculated from equation:

$$v = fnd/60$$

The velocity of  $v_1$ ,  $v_2$ ,  $v_3$ ,  $v_4$  and  $v_5$  are used for design calculation and experiments.

- The power requirements of belt conveyor without and with load were calculated from equations

$$\text{Total power} = P1 \text{ without load} + P2 \text{ with load}$$

- Forces and moments imposed on each leg of the belt conveyor by using the following free body diagram and their calculations at two axes y and x

$$F_{\text{total}} = \text{Resultant force} = (W \text{ raw material} + W \text{ belt} + W \text{ steel} + W \text{ drum} + W \text{ bearing})$$

Weight of raw material on the belt conveyor was calculated from the following equation:

$$Q = 3.6 W . V$$

- Bending moment at the leg of the belt conveyor (BM) can be calculate.
- Normal stress, shear stress, bending stress at the leg of the belt conveyor can be calculated.
- Length of the belt can be determined from equation:

$$L = f(r1 + r2) + 2x + (r2 - r1)^2/4x$$

- Power estimation can be calculate by using following formulae:

Normal reaction for top run

$$R_t = g \times m1 \times l \times \cos$$

Normal reaction for bottom run

$$R_b = g \times m2 \times l \times \cos$$

Where  $m1 = mb + mc$

Resistance to motion of top run

$$Ft = Kr \times R_t$$

Resistance to motion of bottom run

$$Fb = Kr \times R_b$$

Force to raise the material

$$Fr = g \times mc \times l \times \sin$$

Power required = total force x speed

Power of motor = power required / transmission efficiency

## CONCLUSION

The system suggested is easy to install. The system is having greater reliability and protection. The system does not require any complicated components. 🌀

## REFERENCES

1. Avi Levy and Haim Kalman (2001), *Handbook of Conveying and Handling of Particulate Solids*.
2. Aallen Reicks and Michael T Myers (2004), "Bulk Material Handling by Conveyor Belt", Society for Mining Metallurgy & Exploration.
3. David Beavers, David Morrison and David Rea (2005), "Non-Linear Model for Dynamic Analysis of Conveyors".
4. El-Gindy A M, Baiomy MA, Abdelhamed M M and Mosa Sahar A (April 2009), "Design and Fabrication of a Simplified Mechanical Handling System of Rice Straw Baling Operation to Reduce Environment Pollution".
5. Franz Kessler (2006), "Recent Developments in the Field of Bulk Conveying".
6. Guthrie A M and Pilcher J R (April 1968), "The Design of Belt Convey or for Bulk Sugar Handling".

7. Larry Goldbeck (2007), "Improving Belt Conveyor Safety with Better Procedures and Training", 9<sup>th</sup> International Conference on Bulk Materials, Storage, Handling & Transportation.
8. Patrick M McGuire (2009), *Conveyors: Application, Selection, and Integration*, 1<sup>st</sup> Edition, CRC Press.
9. Phillip F Ostwald and Jairo Munoz (1997), *Manufacturing Processes and Systems*, 9<sup>th</sup> Edition, Wiley.
10. Radosaw Zimroz and Robert Król (2009), "Failure Analysis of Belt Convey or Systems for Condition Monitoring Purposes".
11. Raghvendra Singh Gurjar, Arvind Yadav and Pratesh Jayaswal (May 2012), "Failure Analysis of Belt Convey or System in a Thermal Power Plant".
12. Roberts A W (1981), "Economic Analysis in the Optimization of Belt Conveyor Systems".
13. Theunis Rrobbert (2013), *Food Plant Engineering Systems*.
14. Vanamane S S, Mane P A and Inamdar K H (2011), "Design and its Verification of Belt Conveyor System Used for Cooling of Mould Using Belt Comp Software".