



Research Paper

# SYNTHESIS, MODELING, ANALYSIS AND SIMULATION OF STAIR CLIMBING MECHANISM

A S Shriwaskar<sup>1\*</sup> and S K Choudhary<sup>1</sup>

\*Corresponding Author: A S Shriwaskar, ✉ [atulshriwaskar@gmail.com](mailto:atulshriwaskar@gmail.com)

Today due to people loses their body parts due to various reasons it may be trauma or due to accident. The person who loses legs use wheel chair for moment from one place to another. There are various types of chairs available in the market but most of them do not provide any support while climbing support so patient must have to be depending on other people. This paper present stair climbing mechanism by which chair will climb on stair without any assistance. This consist of several mechanisms like star wheel, cylinder piston mechanism, etc.

Keywords: Stair climbing mechanism, Analysis and Simulation, Star wheel, Cylinder position

## INTRODUCTION

This project revels about synthesis, modeling and simulation of mechanism for guiding wheels for climbing mechanism. Machines consist of number of mechanisms for their successful operation and to give desired output. Mechanisms like four bar mechanism, single slider crank mechanism, double slider crank mechanism, etc., are used for transmitting motion, force, torque, etc... Generally a mechanism is designed for the desired performance output of the machine and these mechanisms are being used in case of climbing wheels. In cities the buildings are generally three or four storied and it is not convenient and also financially not easy to fit

electric lifts everywhere. A chain lift can be used by old or disabled person to clime one floor as subjected to lift. In the field of providing mobility for the elderly and disabled, the aspect of dealing with stairs continues largely unresolved. This project focuses on presenting the development of a stair-climbing wheelchair. This wheel chair is adaptable to climbing and descending stair and slopes. Operation on level ground is similar to the operation of a conventional wheel chair.

## IDENTIFICATION OF THE PROBLEM

The following devices are used with assistant for stair climbing and descending commonly,

<sup>1</sup> KDKCE, Nagpur, India.

Figure 1: Climbing – Current Techniques



(a) single person

(b) 4 person stair ascent

(c) 4 person stair descent

Figure 2: Curb and Stair Negotiation – Current Techniques



(a) Curb negotiation

(b) Stair descent 3 persons

these have many of disadvantages and it is described below,

Two common care-worker/assistant based approaches to negotiating stairs are shown in Figure (a) Carrying a person on one’s back and Figures (b) and (c), carrying a person in a lightweight wheelchair. Carrying an elderly or disabled person on ones’ back represents a very efficient and cost effective approach however it also presents high risk of injury for

both persons, back injury is often associated with long term care – despite using all the “right” lifting. Techniques, and combined with the risk of suffering a fall.

When carrying a person in a lightweight wheelchair the number of assistants may vary from two to four, depending on the weight of the passenger and the strength of the assistants vary. Means for stair climbing and descending requires more than single

Figure 3: Slope Negotiation Current Techniques



person. It is not economical and risky operation.

### EARLIER WORK ON STAIR CLIMBING MECHANISM

Murray Lawn and Takakazu Ishimatsu (2003) provide mobility for the elderly and disabled the aspect of dealing with stairs continues largely unresolved. This paper focuses on presenting the development of a stair-climbing wheelchair mechanism with high single step capability. The mechanism is based on front and rear wheel clusters connected to the base (chair) via powered linkages so as to permit both autonomous stair ascent and descent in the forward direction, and high single step functionality for such as direct entry to and from a van. Primary considerations were inherent stability, provision of a mechanism that is physically no larger than a standard powered wheelchair, aesthetics and being based on readily available low cost components.

Moghadam and Mojtaba (2007) gives technological advances of robotic applications in human life, it is necessary to overcome

natural and virtual obstacles such as stairs which are the most known obstacles to the motion of such robots. Several research have been conducted toward the design of stair climbing and obstacle traversing robots during the past decade. A number of robots have been built for climbing stairs and traversing obstacles, such as quadruped and hexapod robots. Although these robots can climb stairs and traverse obstacles, they do not have smooth motion on flat surfaces, which is due to the motion of their legs.

Subhasis Behera and Ananda Sendhil (2003) says that walking machines are advanced alternatives to wheeled locomotion which find applications where wheeled systems cannot be operated. Of these, Stair-climbing machines have come out to be the field, to have been revolutionized in the recent past. Basic purpose of these machines remains serving the handicapped which becomes the objective of the model demonstrated in this paper. The motion analysis has been initiated with its calculation of Degree of freedom and checking the

customized constrains. The success of the model would be realized when the dynamic force analysis of the model is completed and the stability established in the original model which would follow as our next work.

Murray John (2002) gives as we enter the second millennium since the time of Christ there is an increasing mindfulness of the need to focus technology on helping people. This has been in part on account of many countries currently experiencing what is referred to as an “aging population,” that is the number of children born has continued to reduce over a long period of time. The result of this along with many other factors has caused the need for a reducing number of care workers to care for an increasing number of persons. One specific area of need is that of providing increased freedom in terms of mobility for the elderly or disabled. The reasons being to provide an optimum quality of life for the disabled or elderly, and to reduce the load on care workers, the two aspects being closely linked by the conscious sense of being a “burden”.

Autonomy in the area of mobility has always been highly valued, but is sometimes impaired by some form of disability. In many cases this results in reliance on some form of external transport mechanism. In this regard traditional wheelchairs and powered wheelchairs continue to play a vital role. However wheelchairs to date provide a high level of mobility only in artificial or “barrier free” environments. That is there remains a significant gap between the obstacle negotiating ability of a wheelchair and that of the average able bodied person. This aspect is perhaps most apparent when considering stair-climbing. While modern architecture and

new policies continue to make newly built areas as “accessible” as possible to persons with a wide variety of disabilities steps will always be a reality in the “real world”. This thesis focuses on the study of stair-climbing capable mechanisms for the elderly or disabled.

### NEW MECHANISM FOR STAIR CLIMBING

A self propelled wheel chair is adaptable to climbing and descending stairs and slopes. Operation on level ground is similar to the operation of a conventional wheel chair. Propulsion power for both conventional level operation and stair climbing operation is transmitted through the motor and hand

Figure 4: Complete Mechanism of Stair Climbing Chair

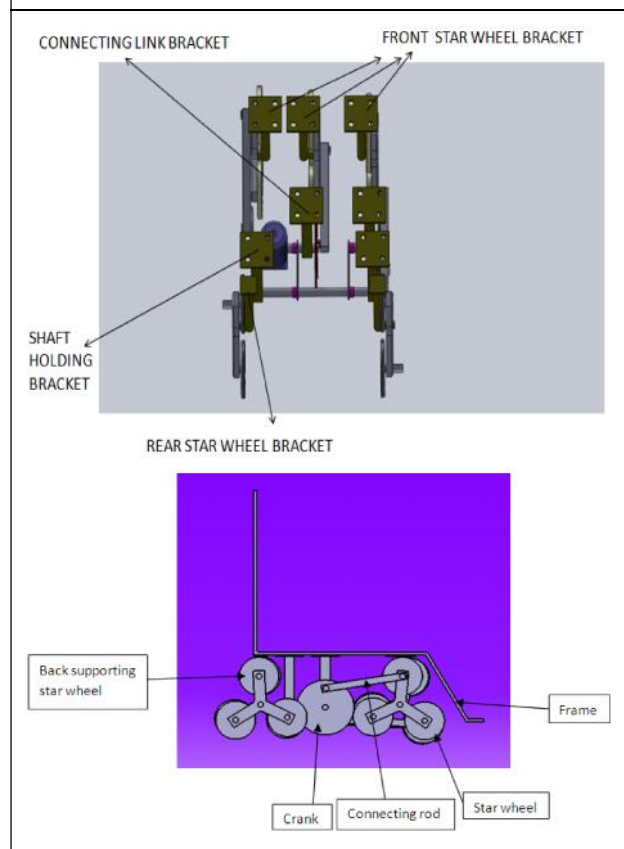

wheels. The front wheels are star wheels which takes power form crank with the help of motor and are mainly used for climbing the stairs. Back star wheels are supporting type which are used to support the chair while climbing and used for travelling on ground or plain surface.

Various parts of the chair are:

- Star wheel
- Connecting rod
- Crank
- Frame
- Supporting star wheel

### DESIGN OF THE STAR WHEEL

Star-wheels have been designed for traversing stairs with 10 cm in height and 15 cm in width (a = 10, b = 15 cm).

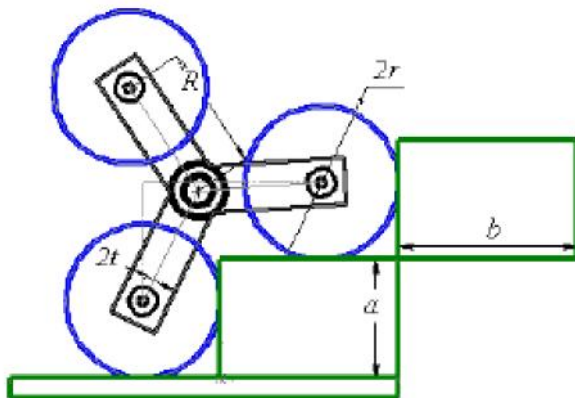

$$R = \sqrt{\frac{a^2 + b^2}{3}}$$

$$R = \sqrt{\frac{10^2 + 15^2}{3}}$$

$$R = 10.44 \text{ cm}$$

Minimum radius of regular wheel

$$r_{min} = \frac{6Rt + a(3b - \sqrt{3}a)}{(3 - \sqrt{3})a + (3 + \sqrt{3})b}$$

$$= \frac{6 * 10.40 * 2 + 10(3 * 15 - \sqrt{3} * 10)}{(3 - \sqrt{3}) * 10 + (3 + \sqrt{3}) * 15}$$

$$r_{min} = 4.80 \text{ cm}$$

Maximum radius of regular wheel

$$r_{max} = \frac{\sqrt{a^2 + b^2}}{2} \frac{\sqrt{10^2 + 15^2}}{2}$$

$$r_{max} = 9.01 \text{ cm}$$

Mean radius  $r = 5.85 \text{ cm}$

Maximum height of stair

$$a_{max} = \sqrt{a^2 + b^2 - r^2}$$

$$= \sqrt{3R^2 - r^2}$$

$$= 13.40 \text{ cm}$$

Total Wt of Whole System = 5 (Weight of Star Wheel) + 7 (Weight of Bracket) + Weight of Drive Gear Motor + 3 (Weight of Connecting Link) + Weight of Shaft 1 + Weight of Shaft 2 + 3 (Weight of Rotary Plate)

$$= 5 \times 5.71 + 7 \times 1.92 + 4.1 + 3 \times 1.33 + 0.95 + 0.3 + 0.45 + 3 \times 1.33$$

$$= 55.77 \text{ kg}$$

Chair weight = 5 kg

Person weight = 70 kg

For rolling applications, generally preferred value the coefficient of friction is 0.2.

Total pulling Weight = Tot. wt of whole system + chair weight + person weight

$$= 55.77 + 5 + 70$$

$$= 130.77 \text{ kg}$$

Hence,

$$\text{Total pulling weight} = 130.77 \text{ kg}$$

$$\text{Maximum Pull} = \text{Total pulling weight} \times \text{Coefficient of friction}$$

$$= 130.77 \times 0.2$$

$$= 26.154 \text{ kg}$$

$$= 260 \text{ N}$$

where, consider  $g = 10 \text{ m/s}^2$

For PCD of sprocket,

$$\text{Conveyor chain pitch } (P) = 12.5 \text{ mm}$$

$$\text{Number of teeth on sprockets } (z) = 13$$

$$\text{Pitch between stairs } (P_c) = 215 \text{ mm}$$

$$\text{Time to travel pitch } (t) = 3 \text{ sec.}$$

$$\text{Pitch Circle Diameter of Sprocket, (PCD)} \\ = \text{Pitch } (P) / \sin(180/z)$$

Hence,

$$\text{PCD of Sprocket} = 12.5 / \sin(180/13)$$

$$= 52.30 \text{ mm}$$

$$= 0.053 \text{ m}$$

$$\text{Required torque} = \text{Maximum pull} \times (\text{PCD of Sprocket} / 2)$$

$$= 260 \times (0.053 / 2)$$

$$= 6.89 \text{ Nm}$$

$$= 7 \text{ Nm}$$

$$\text{Required RPM} = P_c / (t/60) / z / P$$

$$= 215 / 3 / 60 / 13 / 12.5$$

$$= 26.4$$

$$= 26$$

Consider the service factor for the chain is 1.5

Hence,

$$\text{Final output Torque } (T) = \text{Required torque} \times \text{Service factor}$$

$$= 7 \text{ N} \times 1.5$$

$$= 10.5 \text{ Nm}$$

$$\text{Final output RPM } (n) = 26 \text{ rpm}$$

$$\text{Final output Power (HP)} = (2 \times f \times n \times T) / 45000$$

$$= (2 \times f \times 0.5 \times 10.5) / 45000$$

$$= 7.326 \text{ e}^{-4} \text{ HP}$$

### SYNTHESIS OF MECHANISM

The four bar mechanism for climbing wheel chair to be fitted on all four wheels is shown in Figure 1. The length of driver link AB is assumed to be 220 mm. The other link lengths are synthesized by using Fraudensteins equation and Chebechevs spacing method. For synthesizing the mechanism four input output relations assumed are:

1.  $Y = X^2$
2.  $Y = 1/X$

For each of this function the four bar mechanism is synthesized.

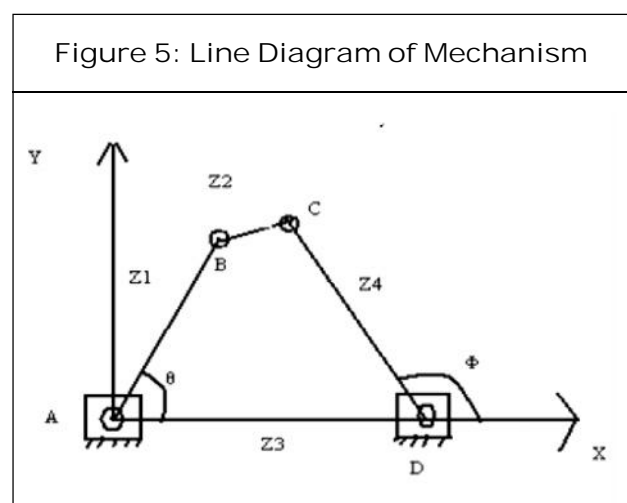



$$0.91K_1 + 0.86K_2 + K_3 = -0.99$$

Therefore

$$K_1 = 0.80, K_2 = -0.53, K_3 = -0.51$$

We have

$$K_1 = Z_1/Z_4$$

$$K_2 = -Z_1/Z_2$$

$$K_3 = Z_3^2 - Z_2^2 - Z_1^2 - Z_4^2/2 * Z_2 * Z_4$$

Solving

$$Z_1 = 83.2 \text{ mm,}$$

$$Z_4 = 104 \text{ mm,}$$

$$Z_2 = 156.98 \text{ mm,}$$

Function	Z <sub>1</sub>	Z <sub>2</sub>	Z <sub>3</sub>	Z <sub>4</sub>
Y = X <sup>2</sup>	83.2	156.98	242.96	104
Y = 1/X	117.52	133.54	246.56	104
Y = X <sup>5</sup>	11.44	19.06	108.52	104
Y = X <sup>3</sup>	24.96	17.82	122.70	104

$$Z_3 = 242.96 \text{ mm}$$

### ANALYSIS OF MECHANISM USING ANSYS V11

Stress and deformation effect in bracket

Figure 7: Loading Conditions

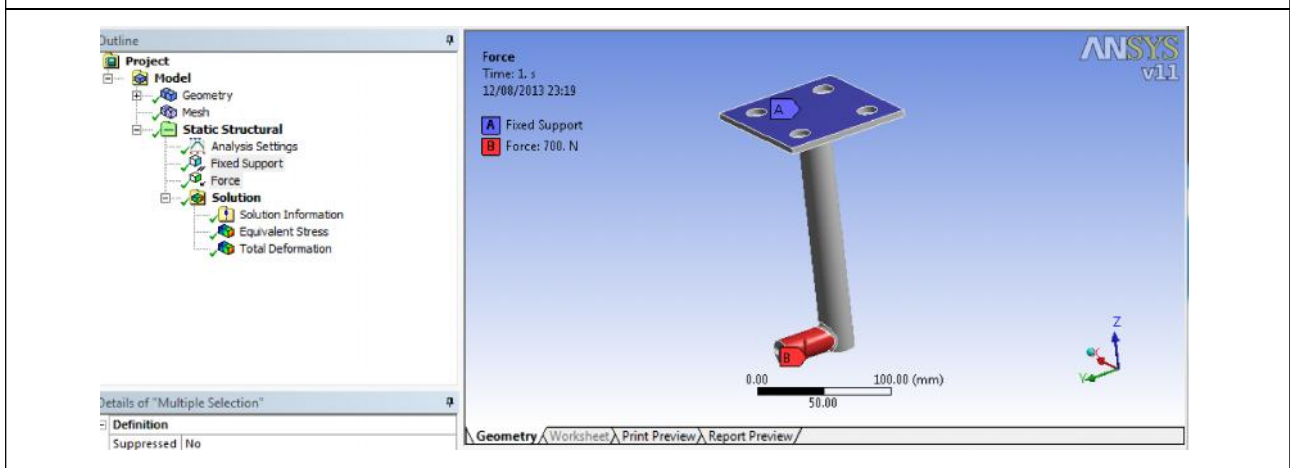

Figure 8: Equivalent Stress

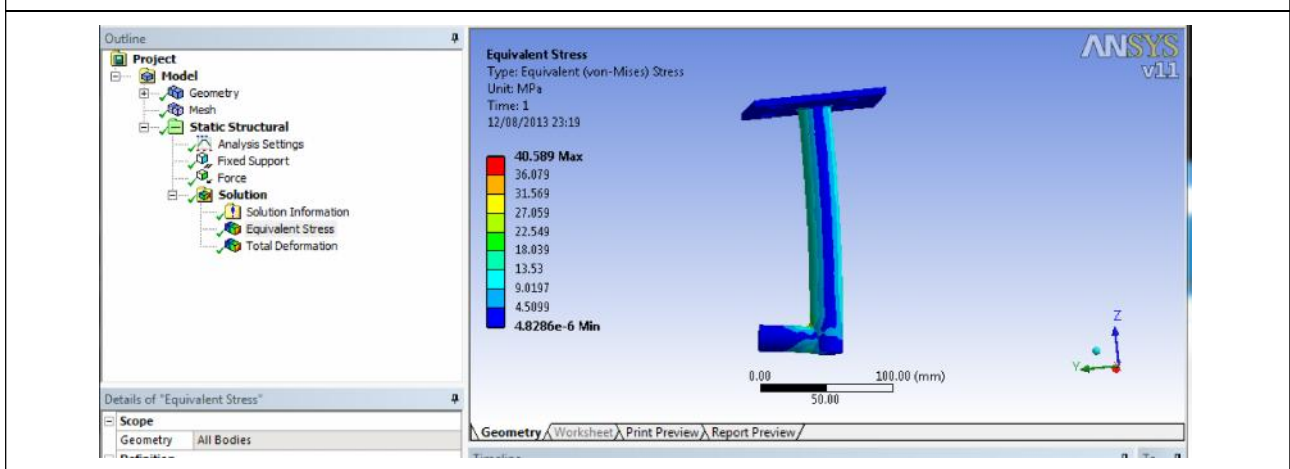
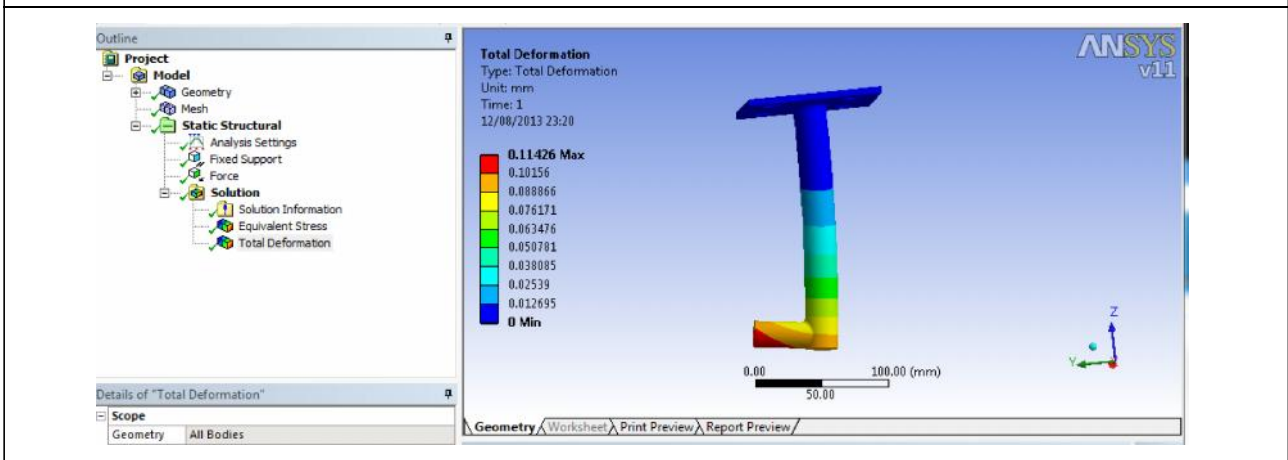



Figure 9: Deformation



## CONNECTING LINK

Figure 10: Applying Rotary Motion

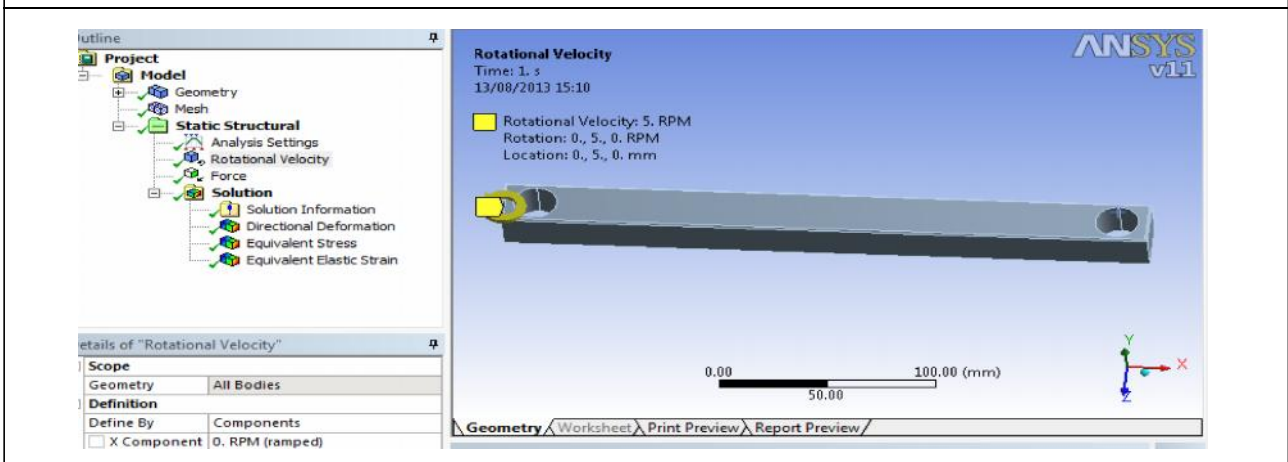

Figure 11: Applying Force

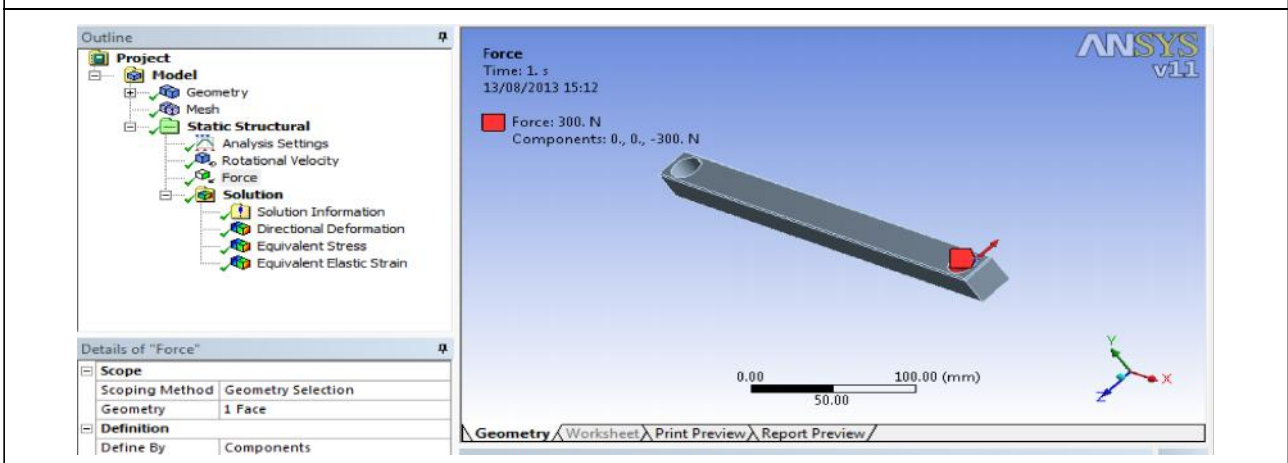

Figure 12: Equivalent Stress

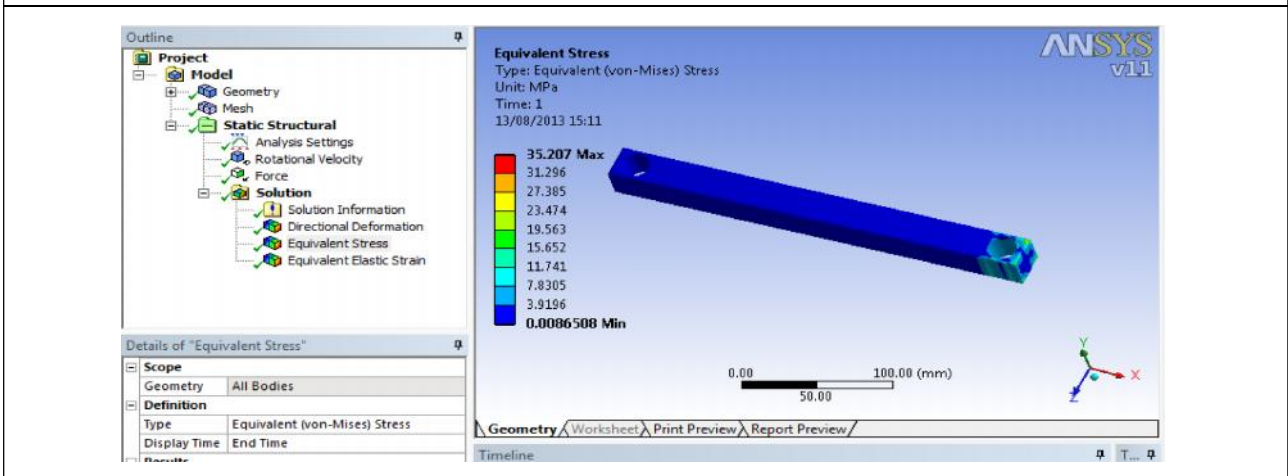

Figure 13: Equivalent Elastic Strain

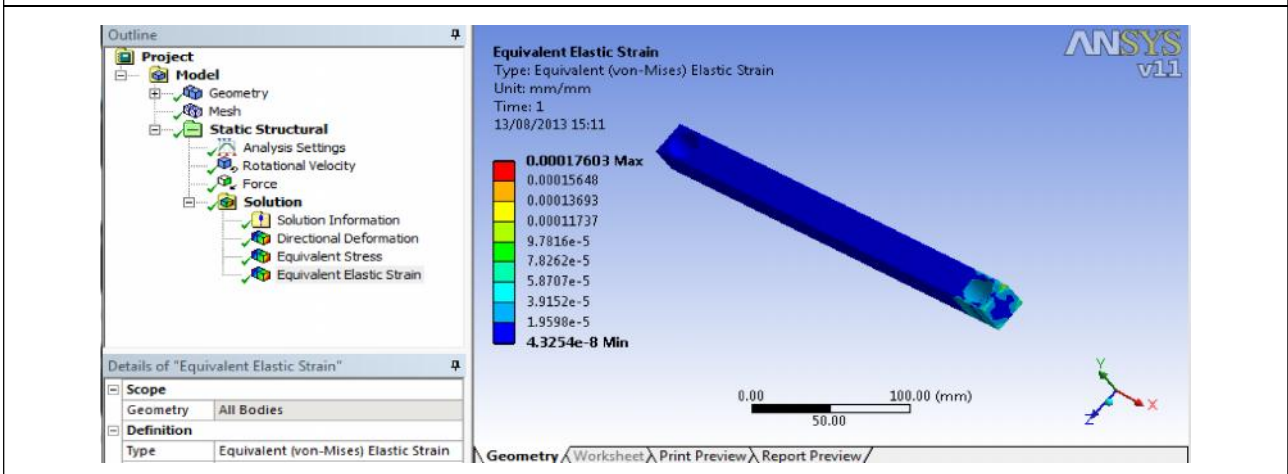

Figure 14: Simulation Result

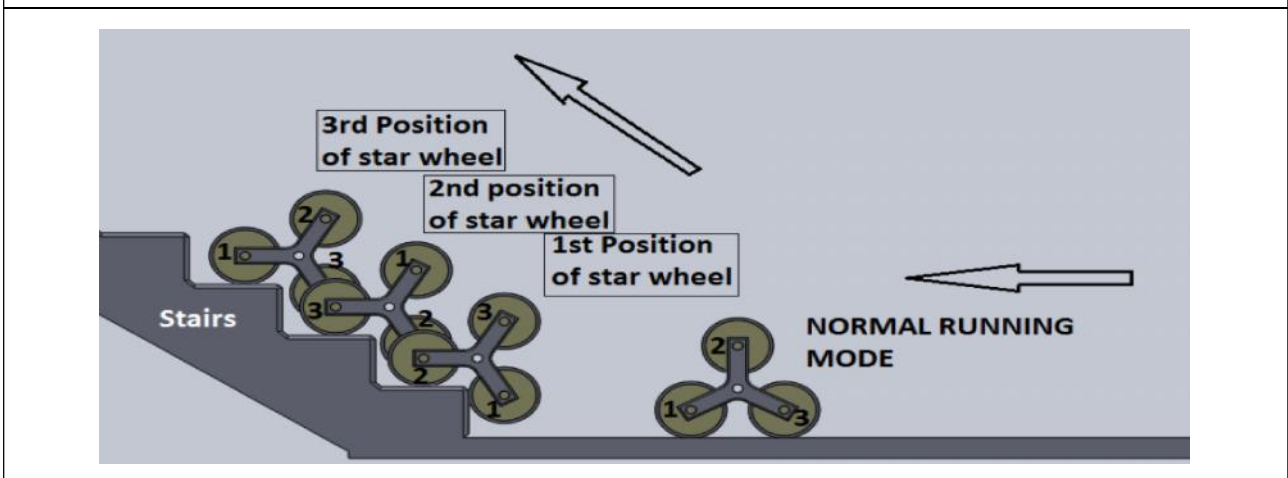
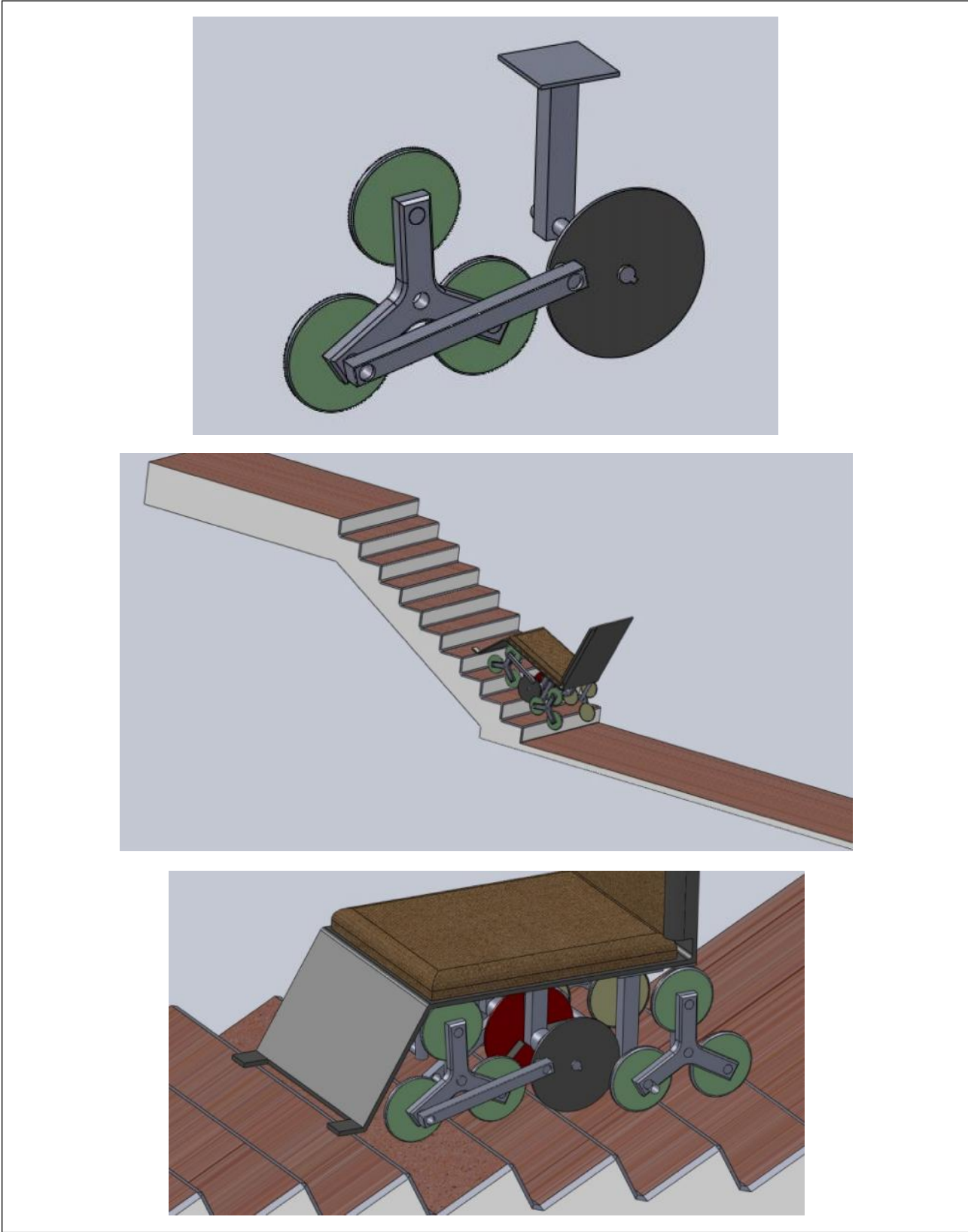

Figure 14 (Cont.)



## CONCLUSION

New chair with three mechanisms like, star wheel and simple driving mechanism will help to prepare a chair that will be able to climb chair without anyone's assistance or with assistance. This chair will helpful to climb chair with a particular height and width. According to the dimensions of stairs we can change dimensions of chair parts. 🌀

## REFERENCES

1. Isabelle Laffont, Bruno Guillon, Christophe Fermanian, Sophie Pouillot, Alexia Even-Schneider, François Boyer, Maria Ruquet, Philippe Aegerter, Olivier Dizien and Frédéric Lofaso (2008), "Evaluation of a Stair-Climbing Power Wheelchair in 25 People with Tetraplegia", *Arch. Phys. Med. Rehabil.*, Vol. 89, October.
2. Murray J Lawn (2002), "Study of Stair-Climbing Assistive Mechanisms for the Disabled Dissertation", December.
3. Murray J Lawn and Takakazu Ishimatsu (2003), "Modeling of a Stair-Climbing Wheelchair Mechanism with High Single Step Capability", *Transactions on Neural Systems and Rehabilitation Engineering*, Vol. 11, No. 3, September.
4. Moghadam M and Mojtaba Ahmadi (2007), "Climbing Robots", *Majid Bioinspiration and Robotics: Walking and Climbing Robots*, September, p. 544.
5. Subhasis Behera and Ananda Sendhil S (2003), "Stair Climbing Mechanism-Thesis", Dr B R Ambedkar National Institute of Technology, Jalandhar.