

Design and Demonstration of Automated Technologies for the Fabrication and Testing of PEM Fuel Cell Systems

Vladimir Gurau , Daniel Cox, Devin Fowler , Matthew Carter, and Adedayo Ogunleke
Department of Manufacturing Engineering, Georgia Southern University, Statesboro, USA
Email: {vgurau, dcox, df02694, mc10203, ao5589}@georgiasouthern.edu

Abstract— This paper describes the research efforts at Georgia Southern University to develop robotic technologies for the fabrication of fuel cell components and stacks, as well as the design and fabrication of a High Temperature Proton Exchange Membrane Fuel Cell (HT-PEMFC) power system to be used as motive power and auxiliary power unit (APU) for a long range, unmanned, fully autonomous forest rover. The paper describes a manufacturing workcell consisting of a *Yaskawa Motoman SDA5F* dual arm robot with machine vision used for sorting, reorientation and stacking fuel cell components in presenters in preparation for their subsequent robotic assembly in fuel cell stacks. It also describes a manufacturing workcell consisting of a *Fanuc LR Mate 200iD* robot, an in-house made computer numerically controlled (CNC) router and programmable logic controller (PLC) used for automated fabrication of graphite bipolar plates for fuel cells. It presents the design and integration of a fully automated test stand used for testing fuel cells up to 4 kWe power and the design and fabrication of a 250 W, 166 cm² active area fuel cell stack prototype. The operation characteristics of this short stack prototype are studied before a larger 3 kW fuel cell system will be built.

Index Terms— Proton Exchange Membrane Fuel Cell (PEMFC), robotic technology, design fabrication and testing of fuel cells

I. INTRODUCTION

At Georgia Southern University (GSU) there is a two-folded research effort to bring fuel cells technology to readiness: (i) development and demonstrations of advanced, automated manufacturing processes for mass production of fuel cell components and stacks, and (ii) design, fabrication and integration of proton exchange membrane fuel cell (PEMFC) systems used as motive power and auxiliary power units (APUs) for unmanned aerial vehicles (UAVs) and autonomous ground vehicles.

Fuel cell stacks and their components are currently being manufactured using mostly laboratory fabrication methods that have been scaled up in size, but do not incorporate high-volume manufacturing methods. According to US Department of Energy (DOE) [1], there

is need to accelerate R&D in manufacturing to prepare advanced manufacturing and assembly technologies that are necessary for low-cost, high volume fuel cell powerplant production. Among the priorities identified by DOE are: efforts to develop technologies for high-speed manufacturing of fuel cell components; to develop automated processes for assembling fuel cell stacks; to develop agile, flexible manufacturing and assembly processes; and to establish flexible automated manufacturing technology facilities. There have been successful demonstrations of automated lines for PEMFC stacks assembly [2-9]. In these demonstrations robots pick up fuel cell components such as gaskets, membrane electrode assemblies (MEAs) and bipolar plates from presenters and place them in the fuel cell stack in a predefined order. Fuel cell components are transferred from their fabrication cells and inserted manually in presenters, all having the same orientation, before the robotic assembly process starts. Manual reorientation of fuel cell components in presenters is a lengthy, tedious process in which human errors are likely. Insertion of a single fuel cell component with a wrong orientation in the stack determines the entire stack to fail in operation. A manual sorting and reorienting fuel cell components may ultimately defeat the advantages brought by automated manufacturing processes of fuel cell components and by robotic assembly process.

This paper describes the design and demonstration of two robotic technologies for automated manufacturing of fuel cells: the first technology demonstrated at GSU [10] uses a *Yaskawa Motoman SDA5F* dual arm robot with integrated machine vision for reorienting and stacking PEMFC components in presenters before their assembly in fuel cell stacks. This technology enables the integration of automated manufacturing processes of fuel cell components with a robotic fuel cell assembly process into a single, fully automated fuel cell manufacturing line. A second technology under development at GSU is for automated manufacturing of graphite bipolar plates for PEMFCs and integrates a *Fanuc LR Mate 200iD* robot with *iRVision 2D* system, an in-house built computer numerical control (CNC) router, programmable logic controller (PLC) and an in-house designed and built pneumatic fixture.

Manuscript received September 4, 2019; revised March 21, 2020.

Vladimir Gurau is the Corresponding author;

Devin Fowler is Currently with GT Technologies, Tallahassee, FL 32303, USA

Another research endeavor at GSU is focused on the design, fabrication, testing and integration of fuel cell power systems and testing equipment for fuel cells. The second part of this paper presents a fully automated fuel cell test stand for testing fuel cells up to 4 kW electrical power which was designed and integrated at GSU. We also present the design and fabrication of a 3kW PEMFC stack that will be used for motive power and as auxiliary power unit (APU) for a long range, unmanned, fully autonomous forest rover that will be built under a USDA-NIFA-SBIR grant.

II. METHODOLOGY

A. Dual Arm Robot with Machine Vision for Sorting, Reorientation and Stacking Fuel Cell Components

This section presents a robotic technology that enables the integration of automated processes for fabrication of fuel cell components with a robotic process for assembling fuel cell stacks into a single, fully automated fuel cell manufacturing line. The technology is used for preparing fuel cell components for the subsequent robotic assembly. This preparation includes component pickup from a bin where they have a random orientation, handling, orientation examination, reorientation and insertion in presenters for the subsequent assembly. In most cases, fuel cell components are slightly asymmetric having a total alpha-plus-beta symmetry angle of 720° according to the Design for Manufacture and Assembly (DFMA) [11] classification system for manual insertion and fastening processes. This means that the angle through which components must be rotated to repeat their orientation is 360° around the axis of insertion and 360° around an axis perpendicular to the former. Fuel cell components are typically only slightly asymmetric, making their orientation examination difficult. PEMFC gaskets and MEAs are also flexible, flat, thin parts which also makes their manipulation challenging. While this technology is applicable to any type of fuel cell components, it was demonstrated for gaskets that were designed and cut in-house for a 166 cm^2 active area high temperature PEM fuel cell (HT-PEMFC) stack. Use of flexible gaskets added to the complexity of the task.

This technology uses a *Yaskawa Motoman SDA5F* dual arm robot with integrated vision system (Fig. 1). The vision system is *COGNEX In-Sight 8000* with *IS8402M-373-50* fixed camera attached to the robot stand through a Swiveling mounting system, a *CIO-Micro-CC I/O* module and desktop computer with *In-Sight Explorer 5.4.0* software.

The algorithm for achieving the task is divided into two stages. The first stage, called the main process consists of picking up the fuel cell components from a bin where they have a random orientation, handling them and inserting them into the presenter. The second stage, the machine vision process and fuel cell component reorientation is executed for the purpose of examining the original component orientation, for taking decisions regarding the procedure required for reorientation and then reorienting them for insertion into the presenter.



Figure 1. *Yaskawa Motoman SDA5F* dual arm robot with *COGNEX In-Sight 8000* vision system used for automated sorting, reorientation and stacking fuel cell components in preparation for a subsequent robotic assembly process.

For the main process, the dual arm robot was programmed to operate in non-coordinated manipulation mode. Each arm cycle consists of two steps. In the first step the left arm picks up a fuel cell component from the bin and brings it in front of the fixed camera for image analysis while the right arm waits for the image analysis results. In the second step, after the image analysis and reorientation of the fuel cell component are completed, the left arm either inserts the component now with the correct orientation in the presenter while the right arm simultaneously picks a new component from the bin, or, if the fuel cell component was transferred to the right arm, it waits until the latter inserts it in the presenter. The robot then withdraws the left arm while simultaneously the right arm brings its fuel cell component in front of the camera. The left arm waits for the image analysis results of the component in the right arm. The cycle of the right arm is identical with that of the left arm but is out of phase one step. The controller counts the number of iterations already executed and if necessary, executes a new iteration. For the main process the robot was programmed in a combination of leadthrough programming using a teach-pendant and off-line programming using *MotoSim EG-VRC* software.

For the second stage, the orientation of the fuel cell component in the bin is examined relative to two axis of rotation simultaneously. The orientation of the fuel cell component is determined through image analysis by identifying a corner with a $5 \text{ mm} \times 45^\circ$ chamfer. A robot arm brings the fuel cell component in front of the fixed camera with the first corner in the camera's field of view. The image is acquired and compared to previously taught images. If the chamfer is identified, the inspection result is "pass", otherwise "fail". If the vision system fails to identify the chamfer at the first corner, the robot arm brings the second corner in the camera's field of view and the image acquisition and analysis repeats. The process repeats until the machine vision system identifies the chamfered corner. When the machine vision system identifies the chamfered corner ("pass"), depending on the position of this corner the robot decides the actions to be taken. It may need to flip the fuel cell component by

transferring it from one hand to the other. This action is equivalent to rotating the fuel cell component 180° about an axis perpendicular to the axis of rotation. For this task the arms operate in coordinated manipulation mode. If necessary, the fuel cell component must be rotated in-plane, about the axis of insertion to bring it in the correct insertion position. This is achieved by rotating the end-effector 180° about its end-of arm. For a more detailed presentation of the work see [10].

To compare the robot vs human productivity, a group of five workers were asked to transfer 15 gaskets from the bin to the presenter as fast as they could while retaining the accuracy and without being told the reason of the experiment. Each worker performed 3 tests and the time necessary to finish the task and the number of misplaced gaskets in the presenter was recorded. The initial orientation of the gaskets in the bin was random in all cases. For this short task all workers outperformed the robot, the averaged cycle time to transfer 1 gasket from the bin to the presenter being 5.81 seconds for workers, compared to 14.35 seconds for the robot. However, the robot will outperform the workers over an eight hour shift due to its constant work pace and due to the fact that it does not require downtime for food and rest and it does not suffer from fatigue. In one instance one worker placed two gaskets with the wrong orientation in the bin. This demonstrates that for such dull, repetitive work cycles human error is possible even for short tasks.

B. Robotic Workcell for Automated Manufacturing of Fuel Cell Graphite Plates

A second automated workcell (Fig. 2) was designed and is currently being integrated at GSU for the demonstration of a fully automated fabrication technology of graphite plates for fuel cells. It consists of a *Fanuc LR Mate 200iD* robot used for graphite plate manipulation, *iRVision 2D* system with *Sony XC-56* camera for quality control, an in-house assembled *Openbuilds* CNC router with *PlanetCNC MK3/4* controller for 4 axes CNC used for machining the flow fields of the graphite plates, a *Productivity 1000* PLC from *Automation Direct* for task coordination and a fixture designed and fabricated in-house with two *AMWSW16* pneumatic swing clamps for automated location and clamping of the plates on the CNC router. The pneumatic swing clamps are controlled by a *NITRA AVS-5121-24D* 5 port (4 way) 2 positions solenoid valve.

The graphite plates are transferred by the robot between a stack of blank plates situated within the robot's work volume and the CNC fixture (Fig. 3). Upon completion of this transfer the robot controller sends a digital output signal to the PLC which acknowledges the CNC controller to start machining the anode flow field on the first planar face of the graphite plate. The CNC controller actuates the solenoid valve to close the pneumatic swing clamps, turns on the spindle and the vacuum and starts machining based on previously loaded G-code. At the completion of this task the CNC controller actuates the solenoid valve to open the pneumatic clamps

and acknowledges the PLC which further communicates with the robot controller to remove the plate. The robot brings the plate to the camera for vision inspection of the machined features and upon a positive result flips the plate over by inserting it on a vertical fixture and by grasping it from the opposite face. It then inserts the plate into the CNC fixture with the second planar face exposed and the communication sequence between the robot controller, PLC and CNC controller repeats. The cathode flow field is machined and the process repeats.

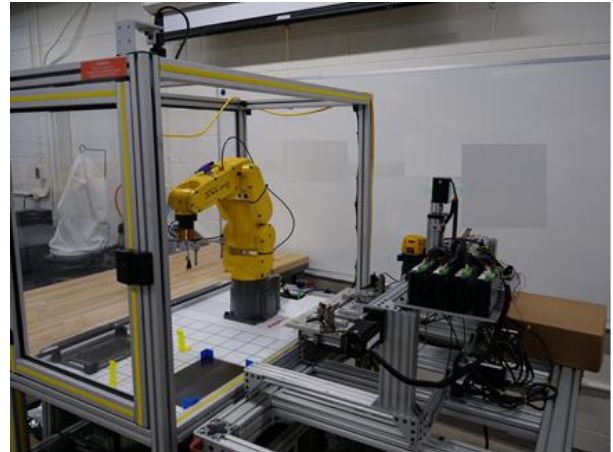

Figure 2. Robotic workcell for automated fabrication of graphite bipolar plates for fuel cells. The figure shows the robot work volume (left) and CNC router (right).

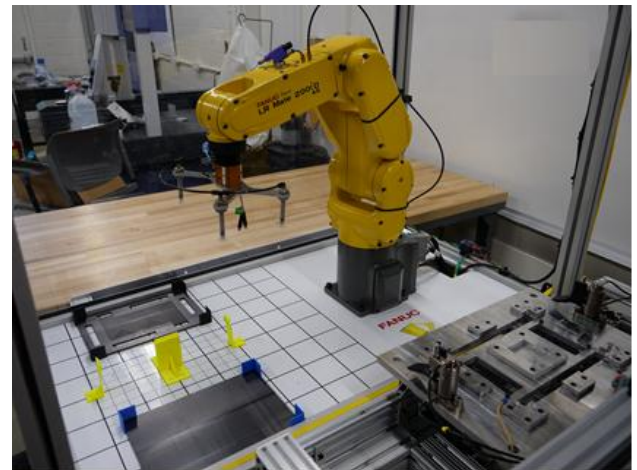

Figure 3. Robot work volume showing the fixture where the finished graphite plates are stacked (far left); fixture for flipping over the plates (middle left); fixture where the blank plates are stacked (close left); fixture on the CNC router containing two AMWSW16 pneumatic swing clamps (right).

Upon a positive result of the cathode flow field vision inspection the robot places the finished plate on a stack within its work volume. This work cycle repeats for a predetermined number of plates.

The robot has been originally programmed off-line and its cycle verified using *RoboGuide* simulation software. The tool frame associated to the end-effector and the user frames associated to the four fixtures in the workcell (Fig.

3) are being determined using the 3-point methods, then the teach pendant programs generated off-line will be uploaded on the robot's controller.

The G-code for machining the anode and the cathode flow fields have been generated using *MasterCAM* software based on 3D design models and the cutting parameters were optimized based on experimental results. The machined anode and cathode flow fields for a 166 cm² active area HT-PEMFC are shown in Fig. 4.

The ladder logic diagram for coordinating the work cycle tasks was programmed using the *Productivity Suite 3.1.1.1* software and downloaded on the PLC card.

The inspection vision process for quality control will be programmed using Fanuc's *iRVision 2D* system.

C. Automated Test Stand for Testing Fuel Cells up to 4 kWe

A second research endeavor at GSU is focused on the design, fabrication, testing and integration of fuel cell power systems. For this purpose, a fully automated test stand for testing fuel cells up to 4 kW electrical power was designed and integrated (Fig. 5). It features an *AMETEK PLA4K-60-1200* electronic programmable load bank, a *Keysight 34970A* data acquisition unit with a *34901A* multiplexer module and *34903A* actuator/switch module, pneumatic lines for safety/reactant gas delivery (Fig. 6) with *Alicat MCR 500/250 SLPM* programmable mass flow controllers, *SBS-H2* hydrogen sensor and a separate unit for fuel cell leak test (lower 4U panel in Fig. 5).

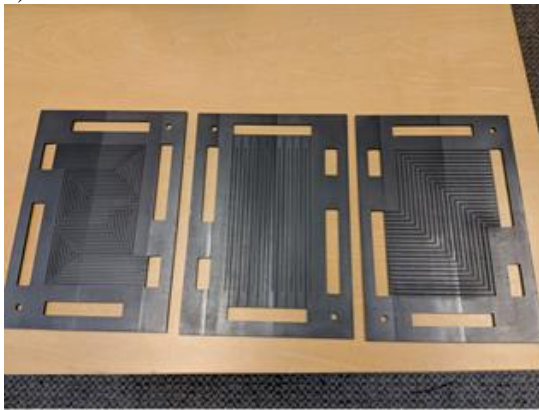

Figure 4. Machined flow fields on graphite bipolar plates for 166 cm² active area HT-PEMFC. Serpentine anode flow field (left); interdigitated cathode flow field (center), and serpentine coolant flow field (right).

The operation of the test stand is controlled through a graphical user interface (GUI) software programmed in-house using *LabVIEW* (Fig. 7) on a laptop connected through GPIB interfaces to the instruments. The multiplexer module reads and communicates to the computer the temperatures of the hydrogen and air lines downstream of the fuel cell and the status of the hydrogen sensors. Besides setting the mass flow rates, the mass flow controllers measure the actual flow rates and the absolute pressures and temperatures upstream of the fuel cell. The actuator/switch module controls the air and hydrogen solenoid valves.

The GUI controller allows the user to change manually the current density level, or to perform automated forward and backward polarization curve measurements in constant current mode. In the case of polarization curve measurements, the user selects the current density increment, the number of points for each curve and the duration of each current density step. The polarization curve data at each current density step is calculated as the average over the last 30 seconds. The thermodynamic and operating parameters of the fuel cell and the polarization curve data points are saved in files with a data acquisition rate of one reading per second. The GUI displays the polarization curve and the evolution in time of the average voltage/cell and the current density.

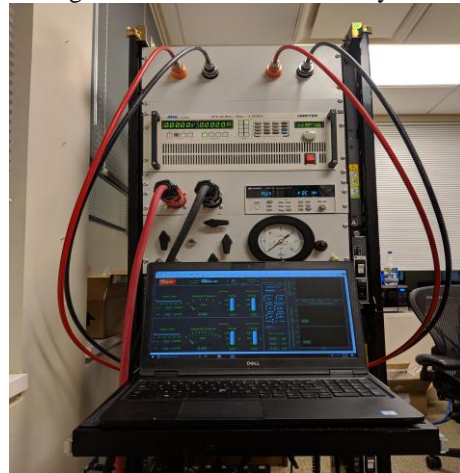

Figure 5. Test stand designed and integrated in-house for testing fuel cells up to 4 kW electrical power.

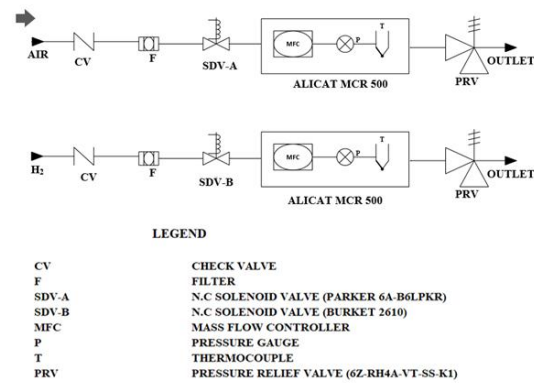

Figure 6. Schematic of the pneumatic lines for safety and delivery of hydrogen and air.

In both manual and automated polarization curve measurements, the set points of the hydrogen and air mass flow rates (g/s) are calculated as a function of input current density using Faraday's law:

$$\dot{m}_{H_2} = \lambda_{H_2} \cdot MW_{H_2} \frac{i \cdot A}{2F} \quad (1)$$

$$\dot{m}_{air} = \lambda_{air} \cdot MW_{air} \frac{i \cdot A}{2F} \quad (2)$$

In (1) and (2), λ represents the hydrogen and air stoichiometric ratios, MW represents the molecular weights of hydrogen and air (g/s), i is the current density

input (A/cm^2), A is the fuel cell's active area (cm^2), F is the Faraday's constant, 96485 (C/equivalent) and the constants 2 and 4 have units of (equivalent/mol H_2) and (equivalent/mol O_2) respectively.

The test stand measurements stop at user's request (E-Stop), upon successful completion of the automated polarization curves or if the hydrogen sensor detects the presence of hydrogen in air. In all situations the controller is programmed to turn off the solenoid valves (Fig. 6) and set the mass flow rates of hydrogen and air to zero.

D. Design and Fabrication of High Temperature PEM Fuel Cell Stack

This section describes the design and fabrication of a 250 W, 166 cm^2 active area PEM fuel cell stack. This shorter stack is tested for gas leaks and optimum operating parameters, and if necessary, the findings will be used to redesign and fabricate a larger, 3 kW fuel cell stack that will be used as motive power and auxiliary power for a long range, unmanned, fully autonomous forest rover.

The arrangements of the fuel cell components in the stack is shown in Fig. 8. The stack consists of 4 active cells and one inactive, cooling cell. The active cells comprise of an *ABM-165* phosphoric acid-doped aromatic polyether membrane electrode assembly (*TPS*® MEA) from *Advent Technologies*, capable of operating up to 200°C.



Figure 7. GUI controller for the fuel cell test stand.

The MEA is bounded on each side by an anode flow field and a cathode flow field machined in-house on graphite bipolar plates (see Fig. 4) using the workcell described above. The manifolds machined on the graphite plates are insulated for gas leaks by 0.0125 inch thick perfluoroalkoxy (PFA) flat gaskets cut using steel rule dies. The cooling cell consists of a coolant flow field machined on one side of a graphite bipolar plate and bounded by a 0.062 inch thick graphite flexible paper sheet (*GTB Grafoil*) from *GrafTech* used as electrical conductive interface and gas insulator. The other side of the graphite bipolar plate has a cathode flow field machined on it. On the other side of the *Grafoil* paper there is a flat (no flow field) / anode flow field bipolar plate. In this configuration, there is one cooling cell followed by two active cells on each side. The last active cells in the stack are in electrical contact with copper current collector plates cut in-house using CNC water jet.

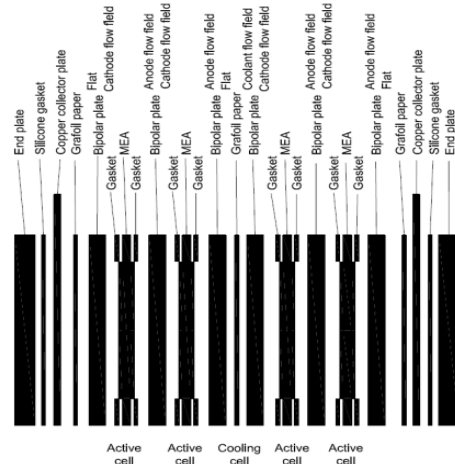

Figure 8. Schematic, exploded view of the short fuel cell stack arrangement.



Figure 9. 250 W, 166 cm^2 active area high temperature PEM fuel cell stack on test stand.

To increase the surface electrical conductivity between the copper current collector plates and graphite bipolar plates there is a *Grafoil* paper placed in-between them. The last components in the stack are the end-plates, one on each side, cut from 0.5 inch thick aluminum using CNC water jet and machined using a *Haas Minimill 2* CNC milling machine. Between the end plates and the copper current collector plates there is a 0.125 inch thick silicone gasket used as electrical and gas insulator. The fuel cell stack is clamped together using ten 3/8-24 UNF tie rod – nut assemblies with 1 inch long, heavy duty die springs that compensate for tie rod elongation at elevated temperatures.

The stack assembly is shown in Fig. 9. The design of this short stack will be tested for anode-to-cathode and overboard gas leaks and for sensitivity to operating parameters such as hydrogen and air stoichiometric ratios and operating temperature using the test stand described above. The stack is cooled using forced air blown through the coolant flow field and the stack temperature is determined by monitoring the coolant and reactant gases temperature at exhaust. The experimental results will be presented elsewhere.

CONFLICT OF INTEREST

The authors declare no conflict of interest.

AUTHOR CONTRIBUTIONS

Vladimir Gurau conceptualized the manufacturing processes, designed and built the fuel cell components, stack, test stand and workcell components, supervised the research and wrote the paper. Devin Fowler integrated the dual arm robot workcell, programmed the robot and vision system, conducted the research and analyzed the data. Matthew Carter integrated the Fanuc robot / CNC workcell, programmed the robot, the PLC and machined the graphite bipolar plates. Adedayo Ogunleke participated in designing and integrating the fuel cell test stand and fuel cell stack. Daniel Cox supervised the research. All authors had approved the final version.

ACKNOWLEDGMENT

This work was made possible with financial support from Georgia Southern University.

REFERENCES

- [1] U. S. Department of Energy: "Roadmap on Manufacturing R&D for the Hydrogen Economy. Draft for Stakeholder/Public Comment," December 2005.
- [2] V. Gurau, D. Fowler, and D. Cox, "Robotic technologies for proton exchange membrane fuel cell assembly," in *Proton Exchange Membrane Fuel Cells*, T. Taner, InTech, London, 2018, ch. 3, pp. 21-34.
- [3] V. Gurau and T. Armstrong-Koch, "Further Improvements of an end-effector for robotic assembly of polymer electrolyte membrane fuel cells," *Energies*, vol. 8, pp. 9452-9463, 2015.
- [4] M. Williams, K. Tignor, L. Sigler, C. Rajagopal, and V. Gurau, "Robotic arm for automated assembly of proton exchange membrane fuel cell stacks," *J. Fuel Cell Sci. Technol.*, vol. 11, pp. 054501-1-5, 2014.
- [5] C. M. Laskowski, "Design-for-manufacture guidelines for automated assembly of Proton Exchange Membrane (PEM) fuel cell stacks," Ph.D. thesis, Rensselaer Polytechnic Institute, Troy, N.Y., USA, 2011.
- [6] C. Laskowski and S. Derby, "Fuel cell ASAP: Two iterations of an automated stack assembly process and ramifications for fuel cell design-for-manufacture," *J. Fuel Cell Sci. Technol.*, vol. 8, pp. 031004-1, 2011.
- [7] Youtube. [Online]. Available: <https://www.youtube.com/watch?v=E-vcRR4mC6w>
- [8] P. Konold, A. Muminovic, and M. Wehrem, "Assembly of fuel cells and stacks with robots," in *Research and Education in Robotics: EUROBOT 2008*, A. Gottscheber et al., Ed. Springer-Verlag, 2009, ch. 3, pp. 168-179.
- [9] [Online]. Available: https://www.youtube.com/watch?v=KhrcHO_qw80
- [10] D. Fowler: "Hydrogen fuel cell gasket handling and sorting with machine vision integrated dual arm robot," MSc. Thesis, Georgia Southern University, Statesboro, GA, USA, 2019
- [11] G. Boothroyd, P. Dewhurst, and W. A. Knight, "Product design for manufacture and assembly," 3rd ed., CRC Press, Boca Raton, 2011

Copyright © 2020 by the authors. This is an open access article distributed under the Creative Commons Attribution License ([CC BY-NC-ND 4.0](https://creativecommons.org/licenses/by-nc-nd/4.0/)), which permits use, distribution and reproduction in any medium, provided that the article is properly cited, the use is non-commercial and no modifications or adaptations are made.



Vladimir Gurau is from Bucharest, Romania, where he graduated with his Engineering Diploma degree in Mechanical and Aeronautical Engineering from the Politechnical Institute of Bucharest in 1987. He obtained his Ph.D. degree in Mechanical Engineering from the University of Miami, Florida in 1998.

He has 10 years of experience in aeronautical and fuel cells industries and more than 20 years

of experience in research and as a licensed professional engineer. He is currently an Assistant Professor in the Department of Manufacturing Engineering at Georgia Southern University, Statesboro, GA, USA. His research expertise is in the areas of fuel cells, robotics and advanced manufacturing. He is the author of more than 45 scientific publications in peer-reviewed journals, book chapters, conference proceedings and patents.

Dr. Gurau is a member of the editorial board of *Energies* and a member of the Society of Manufacturing Engineering.



Daniel Cox is from Gainesville Florida where he also graduated with his BSME with Honors degree and Master of Engineering degree from the University of Florida in 1979 and 1981, respectively. In 1981 he joined the IBM Corporation in Boulder Colorado where he worked as a Manufacturing Engineer. In 1986 he was awarded the prestigious IBM Resident Study Program Award to attend doctoral studies at the University of Texas at Austin. He graduated with his Ph.D. in Mechanical Engineering with specialization in robotics from UT Austin in 1992 where he also worked at the IBM Austin Texas facility as a Robotics and Automation Engineer until 1998.

He joined the University of Texas at Austin in 1998 as a Research Scientist where he was the Associate Director and Program Manager of the Robotics Research Group. In 2001 he joined the faculty at the University of North Florida where he became Professor of Mechanical Engineering. While at UNF he initiated the Manufacturing Innovation Partnership Program, sponsored by the National Science Foundation, to foster industry-academic collaboration. In 2016 he joined Georgia Southern University as Professor and Founding Chair of the Department of Manufacturing Engineering. He remains very active in promoting experiential learning projects for manufacturing engineering students through collaboration with regional industry. His research and teaching interests are in the areas of robotics and automation, advanced manufacturing, and dynamic systems and control engineering.



Devin Fowler is from Jackson, Florida. He graduated with his BSME degree from the University of North Florida in 2016 and obtained his Master of Science degree in Applied Engineering with a concentration in Mechanical Engineering from Georgia Southern University in 2019. He has previously authored a book chapter and a paper published in a peer-reviewed journal in the area of robotics.

Mr. Fowler currently works as a Systems Integration Engineer for GT Technologies in Tallahassee, Florida.



Matthew Carter is from Jacksonville, Florida. He graduated with his Associates degree from Florida Community College, Jacksonville, Florida and with his BSME degree in Mechanical Engineering with a minor in Electrical Engineering from the University of North Florida in 2017. He is currently a Master of Science student in the Manufacturing Engineering program at Georgia Southern University.



Adedayo Ogunleke was born in Ibadan, Southwest Nigeria. He obtained his Bachelor's degree in Electrical and Electronics Engineering from Ladoke Akintola University of Technology, in Ogbomosho, Oyo state, Nigeria in 2015. He worked as a technical support officer until 2018 and is currently completing his Master's degree in Mechanical Engineering at Georgia Southern University where he is also employed as a research assistant in the Department of Manufacturing

Engineering.