



Research Paper

DETERMINATION OF OPTIMUM CUTTING SPEED THROUGH FEA AND PROCESS OPTIMIZATION OF SUPPORT BULK HEAD

Paderu Madan Manohar^{1*} and V Srinivas Reddy²

*Corresponding Author: **Paderu Madan Manohar** ✉ paderu.madan@gmail.com

A missile is a self-propelled guided weapon system. Support bulk head is a thin walled component used to hold bulk head of a missile. The component requires both inside and outside machining. So it needs a special type of fixture to hold the component rigidly. For this, the component is top clamped. Thus it calls for CNC machining. This component is manufactured on a 4-axis turning machine to get dimensional accuracy of the component, to reduce unit cost and labor work. This project is aimed to predict the stable speed range for machining thin-ribbed bulk head support structure with minimum deflection and high surface finish. Harmonic analysis shall be carried out for the support bulk head model, using which the stable speed range is determined. The cutting forces, which were measured experimentally, are applied as input for finite element analysis. The influence of cutting forces on the deflection of bulk head also has been studied. The support bulk head deflection may be influenced by natural frequency of the spindle, if the operating frequency of the spindle matches with it. In order to overcome this problem, free vibration analysis of the high speed spindle unit is performed to determine the natural frequency and mode shapes. Spindle speeds may be selected such that the operating frequency will not match with the natural frequency of the spindle unit. This project is also aimed at optimizing the manufacturing process of the support bulk head. Two different process plans along with NC programs shall be developed to decrease number of setups, which reduces machining time and the unit cost of the component.

Keywords: Support bulk head, Mandrel design, 4-axis CNC turning machine, Harmonic analysis

INTRODUCTION

Support bulk head is a thin walled component used to hold bulk head of a missile. The

component requires both inside and outside machining. So it needs a special type of fixture to hold the component rigidly. For this, the

¹ M.Tech Student, Department of Mechanical Engineering, Mallareddy College of Engineering & Technology, Hyderabad, India.

² Assistant Professor, Department of Mechanical Engineering, Mallareddy College of Engineering & Technology, Hyderabad, India.

component is top clamped. Thus it calls for CNC machining. This component is manufactured on a 4-axis turning machine to get dimensional accuracy of the component, to reduce unit cost and labor work.

High speed machining is one of the emerging cutting processes having tremendous potential compared to conventional machining processes. It is an economically viable alternative to other forms of manufacturing such as forming, casting, and sheet metal build-up. Additionally, high-speed milling processes can produce more accurate and repeatable results, as well as reduce the costs associated with assembly and fixture storage, by allowing several components to be combined into a monolithic machined part. The manufacturing processes of today have become extremely complex owing to the technological advances in last three decades. The status of the modern Manufacturing process is one of the extreme complexity and technological sophistication. The materials and the processes first used to shape the products by casting and hammering have been

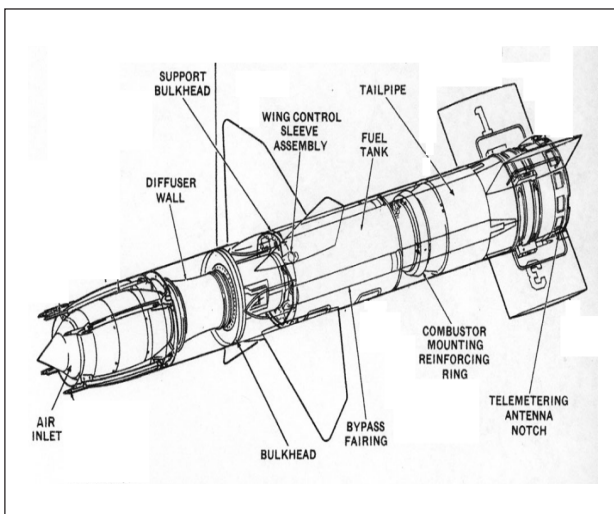

gradually developed over the centuries, using new materials and more complex operations at the increasing rates of production and higher levels of quality.

FINITE ELEMENT ANALYSIS OF SPINDLE

Modeling of the Spindle Unit

High speed spindle used for HSM setup has the following specifications:

Spindle power	5 kW
Spindle speed	6,000 rpm
The bore diameter	40 mm
Length of the spindle unit	330 mm

The 3D model of the spindle assembly is created using UNIGRAPHICS NX software and imported into ANSYS to do finite element analysis. UNIGRAPHICS NX is the world's leading 3D product development solution. This

Figure 1: Isometric View of Tool and Insert Model

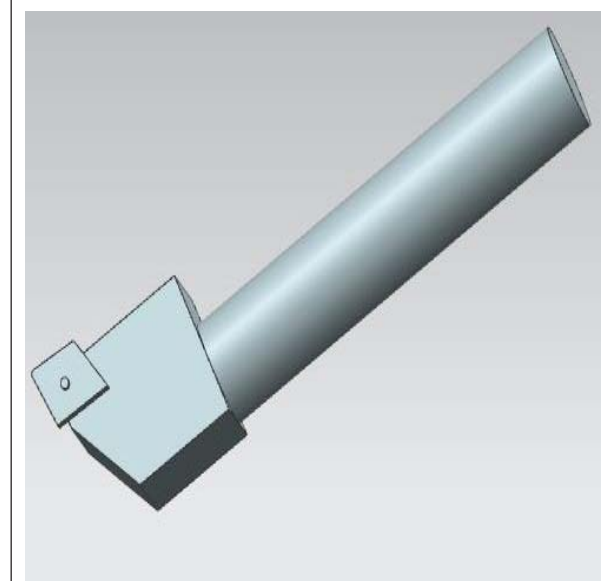
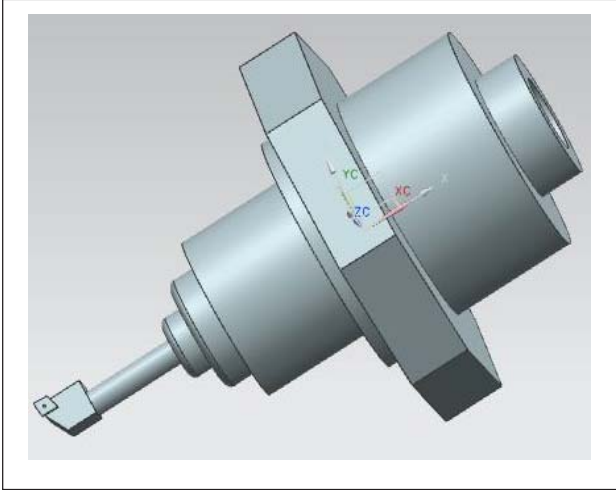

Figure 2: Isometric view of the spindle and tool assembly



software enables designers and engineers to bring better products to the market faster. It takes care of the entire product definition to serviceability. NX delivers measurable value to manufacturing companies of all sizes and in all industries.

MODAL ANALYSIS

Methods for Performing Modal Analysis

There are several methods available for performing modal analysis in Ansys that are given below.

- Subspace method
- Block Lanczos method
- Power Dynamics method
- Reduced method
- Unsymmetric method
- Damped method

From the above, Block Lanczos method is used for performing modal analysis since it is applicable for large symmetric Eigen value problems.

Element Types used:

Name of the Element: SOLID 92

Number of Nodes: 10

DOF: UX, UY & UZ

Figure 3: Finite Element Meshed Model of the High Speed Spindle Unit

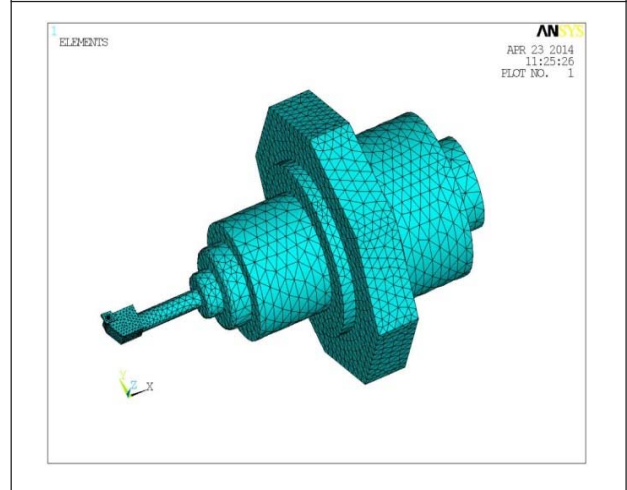

Figure 3 shows the finite element meshed model of the high speed spindle unit which comprises of 12454 elements and 19538 nodes.

MATERIAL PROPERTIES USED IN THE ANALYSIS

Table 1: Material Properties			
Material	Young's Modulus (Mpa)	Poisson's Ratio	Density (Kg/m ³)
High speed steel	2e5	0.3	7850
Carbide cutting tool	5.5e5	0.3	1563

Boundary Conditions

Displacements are constrained at the nodes where the spindle is mounted on the front and rear bearings. Number of modes to expand is

given as 10, so that the first 10 mode shapes of the structure can be obtained.

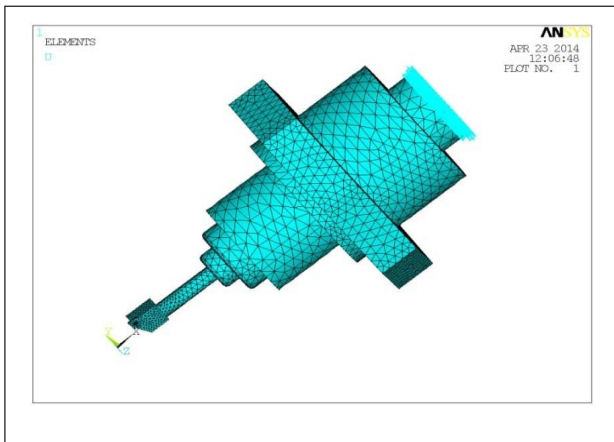

Results: The natural frequency of the spindle with corresponding mode shapes is listed in the below Table.

Table 2: First 10 Natural Frequencies of the Spindle

Mode No	Natural Frequency (Hz)
1	8.8
2	8.81
3	16.46
4	16.49
5	16.93
6	46.51
7	48.96
8	48.98
9	83.6
10	89.53

From the vibration analysis of the high speed spindle unit, it is recommended that the frequencies listed above should be avoided during machining process.

FINITE ELEMENT ANALYSIS OF SUPPORT BULK HEAD COMPONENT

The bulk head support structure having thin wall is considered here for performing harmonic analysis to predict the stable speed ranges. The bulk head support structure is modeled and modal analysis has been done to find out the natural frequencies followed by harmonic analysis has been performed.

The bulk head support structure shown in Figure is considered and finite element harmonic analysis is performed to predict the stable speed range for machining. The structure is modeled in UNIGRAPHICS and imported to ANSYS. Harmonic analysis is performed by using Solid 92, 3-D 10 Node tetrahedral structural solid elements, which has a quadratic displacement behavior and is well suited to model irregular meshes. The element is defined by 10 nodes having three degrees of freedom at each node namely translations in the nodal x, y and z directions. The element has plasticity, stress stiffening, large deflection and large strain capabilities.

As the structure is placed on the machine tool table and clamped at the sides, nodes located at the end surface of the bulk head support are constrained in all degrees of freedom.

MODELING OF BULK HEAD SUPPORT COMPONENT

SOLID92 Input Data

Figure shows the finite element meshed model of the bulk head support which comprises of 10284 elements and 15674 nodes.

Figure 4: Isometric View of Bulk Head Support Model

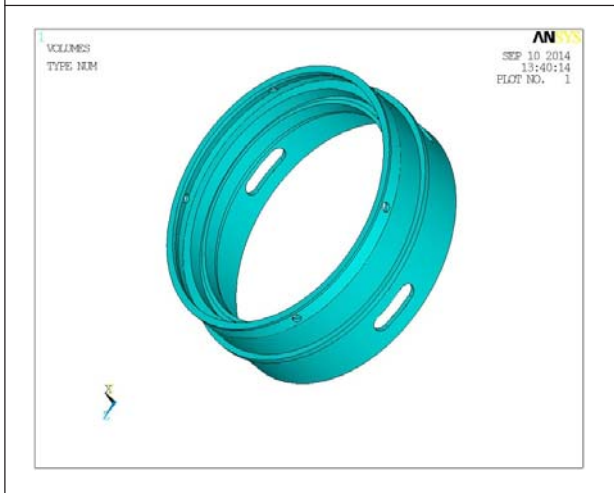

Figure 5: Finite Element Meshed Model of the Bulk Head Support Component

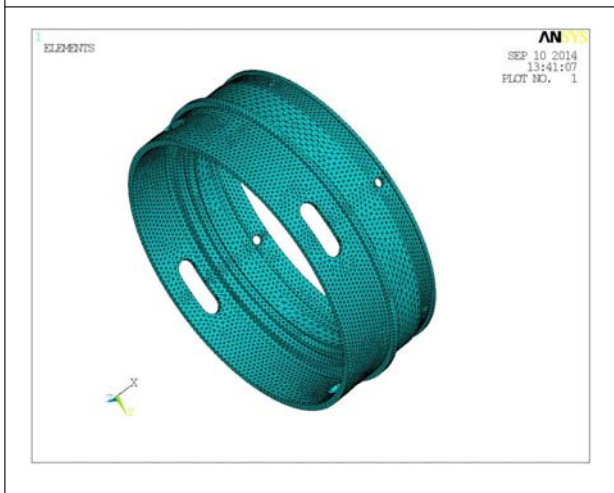

Table 3: Material Properties

Material	Young's Modulus (Mpa)	Poisson's Ratio	Density (Kg/m ³)
Aluminum	0.7e5	0.3	2700

MATERIAL PROPERTIES USED IN THE ANALYSIS

Boundary Conditions

Displacements are constrained at the nodes where the bulk head is mounted on the work

piece holder. As the maximum operating speed of spindle is 100Hz (6000 rpm), frequencies in the range of 0 -100 Hz is of prime importance. So modal analysis of the bulk head support is carried out in the frequency range of 0 -100Hz.

Figure 6: Boundary Conditions for Modal Analysis

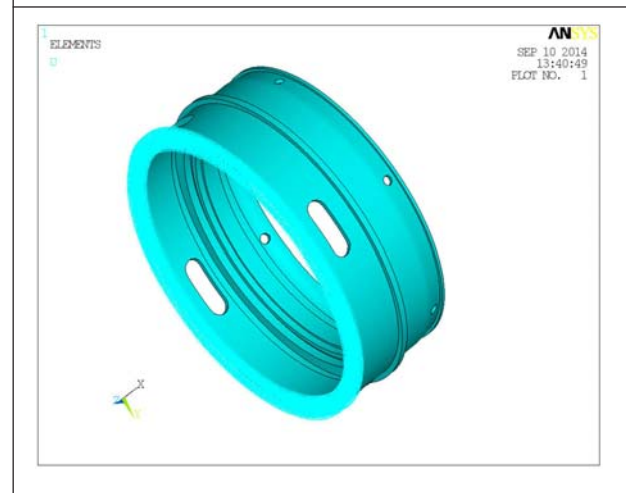

Results: Natural frequencies in the range of (0-100 Hz) is given in the Table 4.

Table 4: Natural Frequencies Between (0-100Hz) of the Bulk Head Support

Mode No	Natural Frequency (Hz)
1	49.832
2	55.053
3	72.302
4	72.402
5	84.215
6	84.254

HARMONIC ANALYSIS OF THE BULK HEAD SUPPORT COMPONENT

From the Figures 10, 11 and 12 it is concluded that the stable speed range for machining the bulk head support component is 10-55Hz i,e

Figure 7: Harmonic Load for Zone 1 Turning

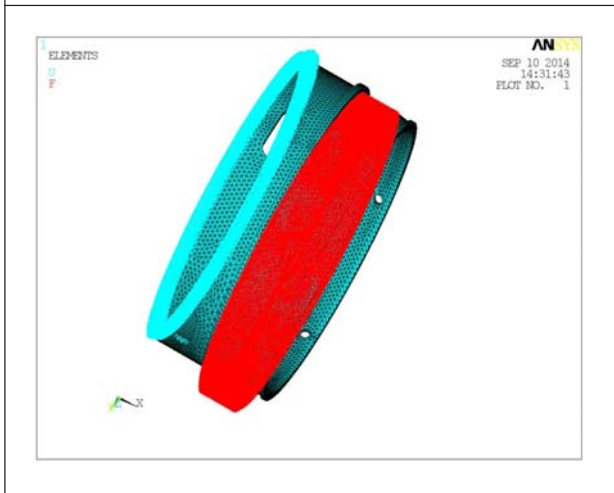

Figure 10: Frequency Vs Amplitude in X-dir Graph for Zone3

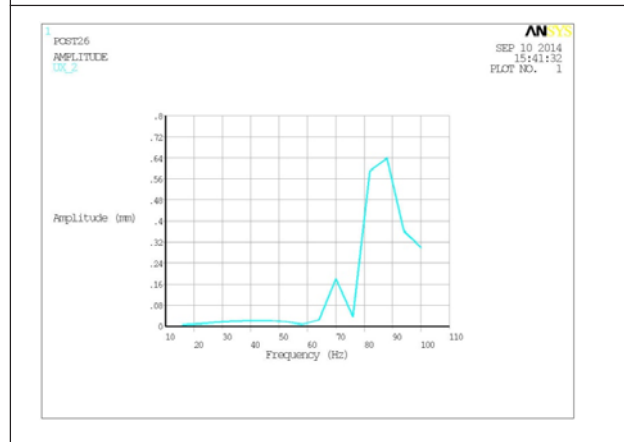

Figure 8: Harmonic Load for Zone 2 Turning

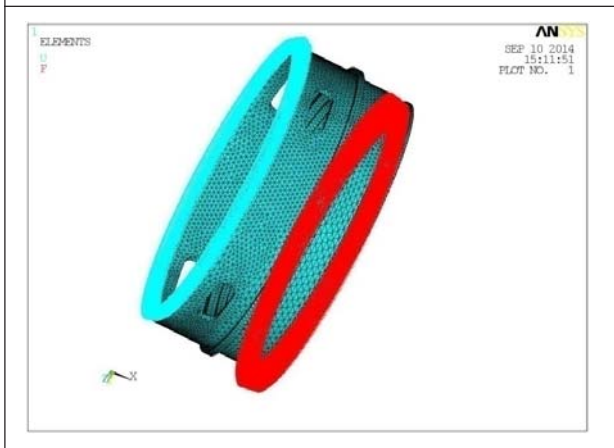

Figure 11: Frequency Vs Amplitude in Y-dir Graph for Zone3

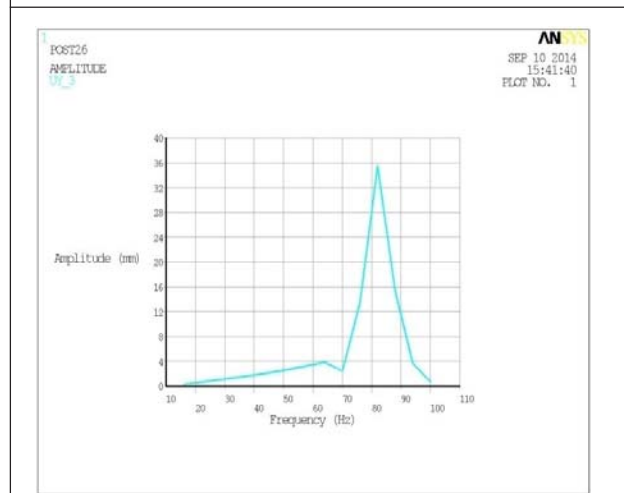

Figure 9: Harmonic Load for Zone 3 Turning

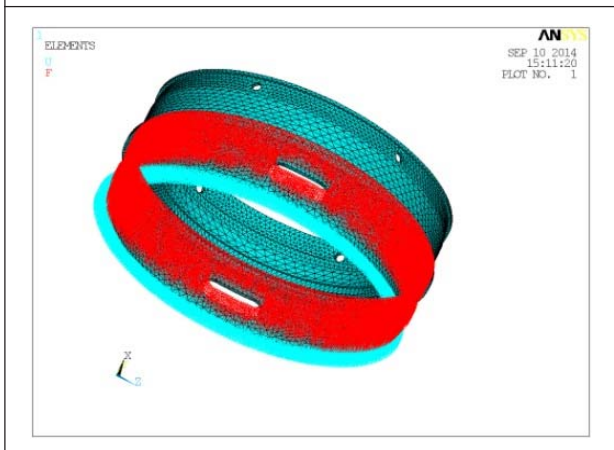
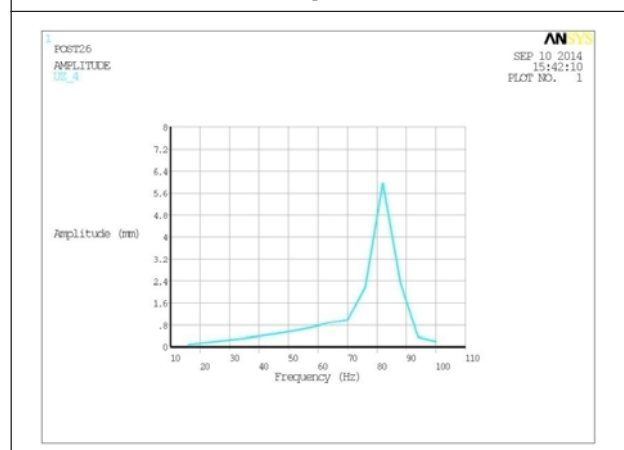

Figure 12: Frequency Vs Amplitude in Z-dir Graph for Zone3



(600-3300 rpm) and 90-100 Hz i,e (5400-6000 rpm). From the analysis it is concluded that if the bulk head support component is machined as per the above speed range in the Zone1, then the component will be free of vibrations and good surface finish can be achieved.

A harmonically varying load simulating the effect of cutting force for an interrupted face turning operation of magnitude 200 N (cutting force) is applied on the face of the component of the structure in zone-3.

Harmonic analysis has been carried out in the frequency range of 10-100Hz (600-6000 rpm). From the analysis results graph of frequency Vs amplitude in X, Y and Z directions have been plotted and shown below.

From the above graph it is concluded that the stable speed range is between 10-60Hz i,e (600-3600 rpm)

From the above graph it is concluded that the stable speed range is between 10-60Hz i,e (600-1800 rpm) and 95-100 Hz i,e (5700-6000 rpm)

From the above graph it is concluded that the stable speed range is between 10-55Hz i,e (600-3300 rpm) and 95-100 Hz i,e (5700-6000 rpm)

From the above graphs is it concluded that the stable speed range for machining the bulk head support component is 10-50Hz i,e (600-3300 rpm). From the analysis it is concluded that if the bulk head support component is machined as per the above speed range in the Zone3, then the component will be free of vibrations and good surface finish can be achieved.

COMPUTER AIDED MANUFACTURING

From the above finite element analysis it is concluded that the stable speed range for machining the bulk head support component is 10-55Hz i,e (600-3300 rpm). Maintaining this stable speed bulk head support component is manufactured on CNC machine.

Methodology used in manufacturing of support is mentioned below:

- Identifying suitable machine.
- Selecting suitable tools for manufacturing thin walled component.
- Listing down the Sequence of operations performed on missile piston.
- Generating tool path at specified cutting speed.
- Generating NC program using NX-CAM software.

MANUFACTURING PROCESS OF BULK HEAD SUPPORT ON CNC MACHINE.

- Raw material is placed on the machine, and degree of freedom is arrested using fixtures.
- The raw material is loaded on the turning machine. internal operations are done first because bulk head support component is thin walled with dimensions 0.8 to 7mm thickness.
- After completing internal operations external operations are done
- After completing turning operations the semi finished component is loaded on the milling machine for drilling operations.

The component is damaged when external operations are performed on machine because the component became hallow after completing internal operations. To avoid damage there should be support from internal when external operations are performed. In order to avoid this rejection problem mandrel is designed.

DESIGN OF MANDREL

Input 2D Drawing for Mandrel

Below shows the 2D drawings of the mandrel with all the required dimensions representations the suits the best for manufacturing the component without any errors.

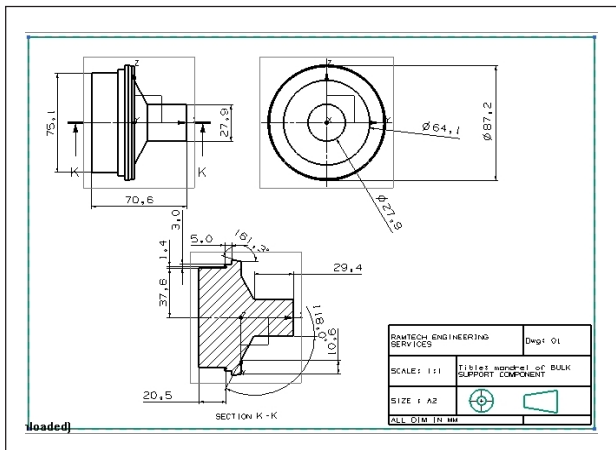

Manufacturing Process for Mandrel

Bulk head support is again machined by using mandrel. After completing internal operation

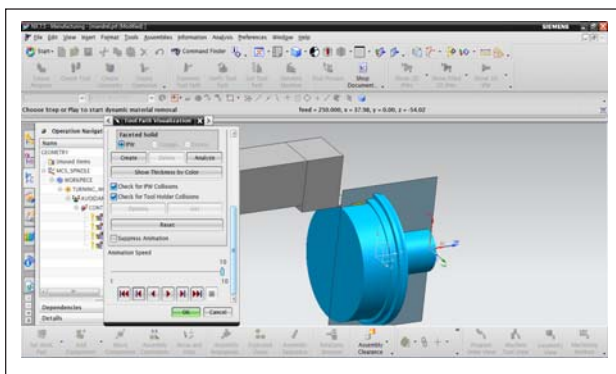

mandrel is used as jig. Mandrel makes contact inside the Bulk head component and this contact supports the component at high cutting speeds and gives high surface finish. The cutting speed preferred to get high surface finish is between 600-3300 rpm which is obtained from analysis report.

The time taken by support component for manufacture on tuning and milling machines is 32m.

RESULTS AND DISCUSSION

Rejection and Reworks of Bulk Head Support

Graphical representation of rejection and reworks of bulk head support without using mandrel.

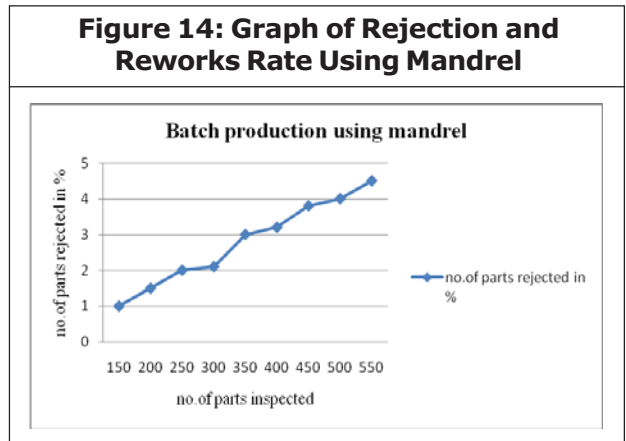
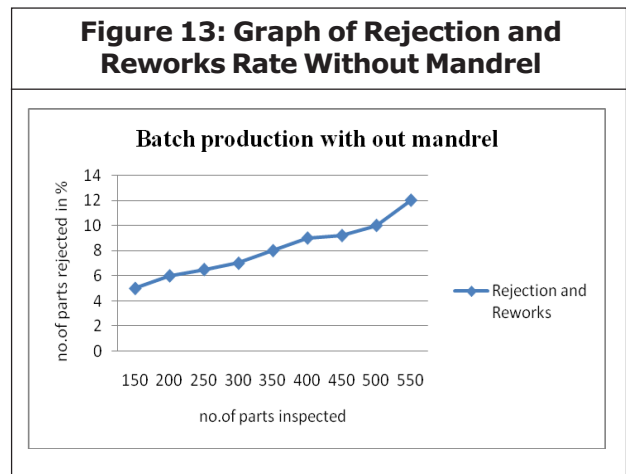

Turning and Milling SETUP			
Set Up	Time Required In Mins.	Machining Costper Hour	Machining Cost/Piece
Turning	08	Rs.800/Hr	Rs.107
Milling	24	Rs.1200/Hr	Rs.480
Total	32		Rs.587

New Setup on Turn Mill			
Set Up	Time Required In Mins.	Machining Costper Hour	Machining Cost/Piece
Turn mill	19:32	RS.1000/HR	322
Total	19:32		322

Graphical representation of rejection and reworks rate of bulk head support shows less rejection and reworks rate when manufactured by using mandrel which will arrest total degree of freedom and supports from internal and allows high cutting speed and increases production rate and reduces machining time, labour cost.

Values taken when components is manufactured on machines

DISCUSSION

The component is damaged when external operations are performed on machine because the component became hallow after completing internal operations. To avoid damage there should be support from internal when external operations are performed. In order to avoid this rejection problem mandrel is designed. Bulk head support is again machined by using mandrel. After completing internal operation mandrel is used as jig. Mandrel makes contact inside the Bulk head component and this contact supports the component at high cutting speeds and gives

high surface finish. The cutting speed preferred to get high surface finish is between 600-3300 rpm which is obtained from analysis report.

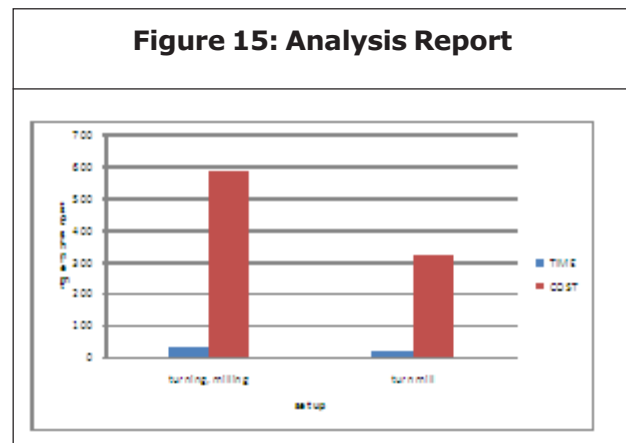

CONCLUSION

1. bulk head support is modeled using unigraphics software NX_CAD
2. Harmonic analysis on the bulk head support is concluded that the stable speed range for range for machining the bulk head support component is 10-50Hz i.e (600-3300 rpm), then the component will be free of vibrations and good surface finish can be achieved.

3. From the vibration analysis of the high speed spindle unit, it is recommended that the frequencies listed in chapter finite element analysis of spindle should be avoided during machining process.
4. Graphical representation of harmonic analysis on bulk head support at different cutting speed is shown in chapter finite element analysis.
5. Mandrel is designed to support the component from internal and to reduce the rejection rate.
6. NC program is generated using unigraphics software NX_CAM
7. Optimized process plan for manufacturing support component is turn mill machine and it is graphically represented in results.
8. Graphical representation of time and cost is shown in results along rejection and reworks rate.
9. The total time required for the manufacturing of the component is reduced.
10. The production cost of the product is also reduced.

REFERENCES

1. Abele E, Altintas Y and Brecher C (2010), "Machine tool spindle units", *CIRP Annals – Manuf. Technol.*, Vol. 59, pp. 781-802.
2. Abele E, Altintas Y and Brecher C (2010), "Machine tool spindle units", *CIRP Annals – Manuf. Technol.*, Vol. 59, pp. 781-802.
3. Choi J K and Lee D G (1997), "Characteristics of a spindle bearing system with a gear located on the bearing span", *Int. J. Mech. Tool. Manuf. Pergamon*, Vol. 37, pp. 171-173.
4. Li C, Ding Y and Lu B (2009), "Development and Key Technology in High Speed Cutting", *J. Qingdao Technol. Univ.*, Vol. 30, pp. 7-16.
5. Li C, Ding Y and Lu B (2009), "Development and Key Technology in High Speed Cutting", *J. Qingdao Technol. Univ.*, Vol. 30, pp. 7-16.
6. Li W, Pu H, Liu Q, Chen G and Zhang S (2009), "ANSYS-Based dynamic analysis of high-speed motorized spindle", *Int. Conf. Comput. Eng. Technol.*, pp. 336-340.
7. Lin Z C and Chang J S (2007), "The building of spindle thermal displacement model of high speed machine center", *Int. J. Adv. Manuf. Technol.*, Vol. 34, pp. 556-566.
8. Lin Z C, and Chang J S (2007), "The building of spindle thermal displacement model of high speed machine center", *Int. J. Adv. Manuf. Technol.*, Vol. 34, pp. 556-566.